

Click [here](#) for production status of specific part numbers.

# MAX33072E/MAX33073E +3V to +5.5V, Polarity Invert RS-485 Half-Duplex Transceiver with $\pm 65\text{V}$ Fault Protection, $\pm 40\text{V}$ CMR, and $\pm 40\text{kV}$ ESD

## General Description

The MAX33072E/MAX33073E are a family of fault-protected RS-485/RS-422 transceivers with high  $\pm 65\text{V}$  protection for overvoltage conditions on the communication bus lines, ensuring robust protection in harsh industrial environments. Both devices have  $\pm 40\text{V}$  of common-mode range (CMR) within  $V_{\text{CCH}}$  (+4.5V to +5.5V), exceeding the RS-485 standard of -7V to +12V, suitable for electrically noisy environments where different systems have shifting ground levels relative to each other. They also incorporate a high ESD protection circuit capable of protecting against  $\pm 40\text{kV}$  of ESD HBM (human body model) for driver outputs and receiver inputs (A and B data lines). Each device contains one driver and one receiver and operates over the +3V to +5.5V supply range, making it convenient for designers to use one part with either +3.3V or +5V supply voltages across multiple end equipment.

These devices feature a polarity selection input (POL) that swaps the A and B data lines, allowing for software correction of cross-wired field cables.

The MAX33072E features slew-rate-limited outputs for data rates up to 500kbps, while the MAX33073E is rated up to 2Mbps for applications requiring higher bandwidth. These transceivers are optimized for robust communication in noisy environments. A true failsafe feature guarantees a logic-high on the receiver output when the inputs are open or shorted. Driver outputs are protected against short-circuit conditions. The receivers feature a 1/8 unit load input impedance, allowing up to 256 transceivers on a bus. The MAX33072E/MAX33073E are available in 8-pin SOIC and operate over the  $-40^{\circ}\text{C}$  to  $+125^{\circ}\text{C}$  temperature range.

## Applications

- Industrial Automation Equipment
- Home and Building Automation
- Agriculture and Heavy Machinery
- Power Supply and UPS
- Elevator Control
- Motion Controllers

## Benefits and Features

- Integrated Protection for Robust Communication
  - Protection on Driver Outputs/Receiver Inputs (A, B Data Lines)
    - $\pm 65\text{V}$  Fault Protection Range on Driver Outputs/Receiver Inputs
    - $\pm 40\text{V}$  Common-Mode Range on Driver Outputs/Receiver Inputs
    - $\pm 40\text{kV}$  Human Body Model (JEDEC JS-001-2017) ESD Protection
    - $\pm 15\text{kV}$  Air Gap Discharge (IEC 61000-4-2) ESD Protection
    - $\pm 10\text{kV}$  Contact Discharge (IEC 61000-4-2) ESD Protection
  - Hot-Swap Protection
  - Short Circuit Protection
  - Thermal Shutdown
  - True Fail-Safe Guarantees Known Receiver Output State
  - Wide Operating Temperature Range from  $-40^{\circ}\text{C}$  to  $+125^{\circ}\text{C}$
- High-Performance Transceiver Enables Flexible Designs
  - Compliant with RS-485 EIA/TIA-485 Standard
  - 500kbps (MAX33072E), 2Mbps (MAX33073E) Maximum Data Rate
  - 3V to 5.5V Supply Range
  - 1/8 Unit Load for up to 256 Devices on the Bus

[Ordering Information](#) appears at end of data sheet.

MAX33072E/MAX33073E

+3V to +5.5V, Polarity Invert RS-485 Half-Duplex Transceiver with  $\pm 65\text{V}$  Fault Protection,  $\pm 40\text{V}$  CMR, and  $\pm 40\text{kV}$  ESD

### Simplified Block Diagram

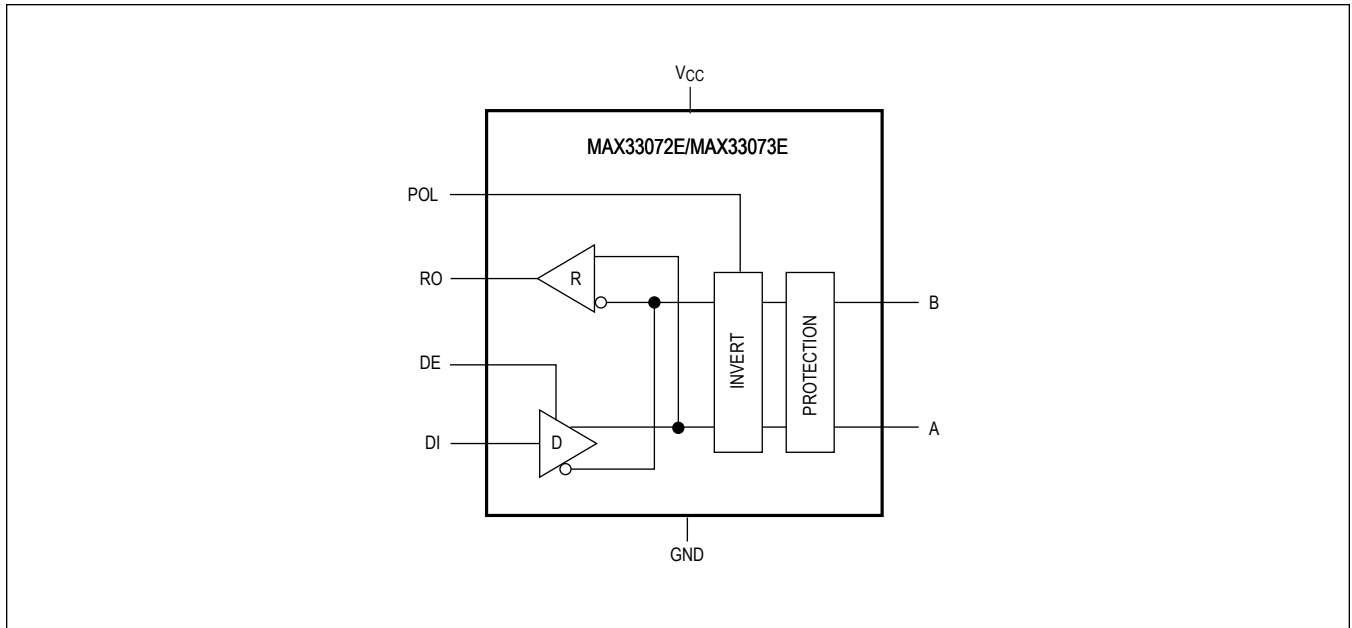

## TABLE OF CONTENTS

General Description . . . . .	1
Applications . . . . .	1
Benefits and Features . . . . .	1
Simplified Block Diagram . . . . .	2
Absolute Maximum Ratings . . . . .	6
Package Information . . . . .	6
SOIC . . . . .	6
Electrical Characteristics . . . . .	6
Typical Operating Characteristics . . . . .	13
Pin Configuration . . . . .	14
SOIC . . . . .	14
Pin Description . . . . .	14
Detailed Description . . . . .	15
Driver . . . . .	15
Receiver . . . . .	15
$\pm 65\text{V}$ Fault Protection . . . . .	15
$\pm 40\text{V}$ Common-Mode Range . . . . .	16
True Fail-Safe . . . . .	16
Hot-Swap Inputs . . . . .	16
Thermal Shutdown Protection . . . . .	16
Applications Information . . . . .	17
256 Transceivers on the Bus . . . . .	17
Typical Application . . . . .	17
Power Considerations for the MAX33072E/MAX33073E . . . . .	17
PCB Layout Considerations . . . . .	18
ESD Protection . . . . .	18
ESD Test Conditions . . . . .	18
Human Body Model (HBM) . . . . .	18
IEC 61000-4-2 . . . . .	19
Typical Application Circuit . . . . .	20
Typical RS-485 Network . . . . .	20
Ordering Information . . . . .	21
Revision History . . . . .	22

## LIST OF FIGURES

---

Figure 1. Driver DC Test Load .....	9
Figure 2. Driver Timer Test Circuit .....	9
Figure 3. Driver Propagation Delays .....	10
Figure 4. Driver Enable and Disable Times ( $t_{DZH}$ , $t_{DZL}$ ) .....	10
Figure 5. Driver Enable and Disable Times ( $t_{DZH}$ , $t_{DZL}$ ) .....	11
Figure 6. Receiver Propagation Delay Test Circuit .....	11
Figure 7. Receiver Propagation Delays .....	12
Figure 8. Human Body ESD Test Model .....	18
Figure 9. Human Body Current Waveform .....	19
Figure 10. IEC 61000-4-2 ESD Test Model .....	19
Figure 11. IEC 61000-4-2 ESD Generator Current Waveform .....	20

---

MAX33072E/MAX33073E      +3V to +5.5V, Polarity Invert RS-485 Half-Duplex  
Transceiver with  $\pm 65V$  Fault Protection,  
 $\pm 40V$  CMR, and  $\pm 40kV$  ESD

---

**LIST OF TABLES**

---

Table 1. Transmitter Truth Table.....	15
Table 2. Receiver Truth Table.....	15

# MAX33072E/MAX33073E

+3V to +5.5V, Polarity Invert RS-485 Half-Duplex Transceiver with  $\pm 65V$  Fault Protection,  $\pm 40V$  CMR, and  $\pm 40kV$  ESD

## Absolute Maximum Ratings

$V_{CC}$ .....	-0.3V to +6V	Operating Temperature Range .....	-40°C to +125°C
RO .....	-0.3V to $V_{CC} + 0.3V$	Junction Temperature .....	+150°C
DE, DI, POL.....	-0.3V to +6V	Storage Temperature Range .....	-65°C to +150°C
A, B (Continuous) .....	-70V to +70V	Lead Temperature (soldering, 10s).....	+300°C
Short-Circuit Duration (RO, A, B) .....	Continuous	Soldering Temperature (reflow) .....	+260°C
Continuous Power Dissipation			
8-Pin SOIC +70°C (derate 7.6mW/°C above +70°C).	606.1mW		

Stresses beyond those listed under "Absolute Maximum Ratings" may cause permanent damage to the device. These are stress ratings only, and functional operation of the device at these or any other conditions beyond those indicated in the operational sections of the specifications is not implied. Exposure to absolute maximum rating conditions for extended periods may affect device reliability.

## Package Information

### SOIC

Package Code	S8+4
Outline Number	<a href="#">21-0041</a>
Land Pattern Number	<a href="#">90-0096</a>
<b>Thermal Resistance, Four-Layer Board:</b>	
Junction to Ambient ( $\theta_{JA}$ )	132°C/W
Junction to Case ( $\theta_{JC}$ )	38°C/W

For the latest package outline information and land patterns (footprints), go to [www.maximintegrated.com/packages](http://www.maximintegrated.com/packages). Note that a "+", "#", or "-" in the package code indicates RoHS status only. Package drawings may show a different suffix character, but the drawing pertains to the package regardless of RoHS status.

Package thermal resistances were obtained using the method described in JEDEC specification JESD51-7, using a four-layer board. For detailed information on package thermal considerations, refer to [www.maximintegrated.com/thermal-tutorial](http://www.maximintegrated.com/thermal-tutorial).

## Electrical Characteristics

( $V_{CC} = 3.0V$  to  $3.6V$  and  $V_{CC} = 4.5V$  to  $5.5V$ ,  $T_A = T_{MIN}$  to  $T_{MAX}$ , unless otherwise noted. Typical values are at  $V_{CC} = 5.0V$  and  $T_A = +25^\circ C$ . POL = 0V (Note 1))

PARAMETER	SYMBOL	CONDITIONS	MIN	TYP	MAX	UNITS
<b>POWER</b>						
Supply Voltage	$V_{CCL}$	Low range	3		3.6	V
	$V_{CCH}$	High range	4.5		5.5	
Supply Current	$I_{CC}$	DE = high, no load, no switching		6		mA
<b>DRIVER</b>						
Differential Driver Output	$ V_{OD} $	Figure 1a, $R_L = 54\Omega$	1.5			V
		Figure 1a, $R_L = 100\Omega$	2.0			
		Figure 1b	1.5			
External Common Mode Voltage	$V_{CM}$	Figure 1b, $V_{CC} = V_{CCL}$	-25		+25	V
		Figure 1b, $V_{CC} = V_{CCH}$	-40		+40	
Change in Magnitude of Differential Driver Output Voltage	$\Delta V_{OD}$	$R_L = 54\Omega$ or $100\Omega$ , Figure 1a (Note 2)	-0.2		+0.2	V
Driver Common-Mode Output Voltage	$V_{OC}$	$R_L = 54\Omega$ or $100\Omega$ , Figure 1a	1	$V_{CC}/2$	3	V

**Electrical Characteristics (continued)**

( $V_{CC} = 3.0V$  to  $3.6V$  and  $V_{CC} = 4.5V$  to  $5.5V$ ,  $T_A = T_{MIN}$  to  $T_{MAX}$ , unless otherwise noted. Typical values are at  $V_{CC} = 5.0V$  and  $T_A = +25^\circ C$ . POL = 0V (Note 1))

PARAMETER	SYMBOL	CONDITIONS	MIN	TYP	MAX	UNITS
Change in Magnitude of Common Mode Voltage	$\Delta V_{OC}$	$R_L = 54\Omega$ or $100\Omega$ , Figure 1a (Note 2)	-0.1		+0.1	V
Single-Ended Driver Output Voltage High	$V_{OH}$	A or B output, output is high, $I_{SOURCE} = 3mA$	2.4	$V_{CC}-0.2$		V
Single-Ended Driver Output Voltage Low	$V_{OL}$	A or B output, output is low, $I_{SINK} = 3mA$			0.2	V
Driver Short-Circuit Output Current	$I_{SC\_DR}$	$-65V \leq (V_A \text{ or } V_B) < 0V$ or $V_{CC} < (V_A \text{ or } V_B) \leq +65V$ (Note 3)			450	mA
Average Driver Short-Circuit Output Current	$I_{AVG\_SCDR}$	$0V \leq (V_A \text{ or } V_B) \leq V_{CC}$			450	mA
<b>RECEIVER</b>						
Input Current (A, B)	$I_A, I_B$	DE = low, $0V \leq V_{CC} \leq 5.5V$	$V_{CM} = +40V$		410	$\mu A$
			$V_{CM} = -40V$	-424		
Receiver Input Resistance	$R_{IN}$	Over $V_{CM}$ range	96			k $\Omega$
Common Mode Voltage Range	$V_{CM}$	$V_{CC} = V_{CCL}$ $V_{CC} = V_{CCH}$	-25		+25	V
			-40		+40	
Receiver Differential Threshold Voltage Rising	$V_{TLH}$	Over $V_{CM}$ range			-50	mV
Receiver Differential Threshold Voltage Falling	$V_{THL}$	Over $V_{CM}$ range	-200			mV
Receiver Input Hysteresis	$\Delta V_{TH}$			100		mV
Differential Input Capacitance	$C_{A\_B}$	Measured between A and B, $f = 1MHz$		50		pF
<b>LOGIC OUTPUT</b>						
RO Output Logic-High Voltage	$V_{OH}$	$I_{SOURCE} = 3mA$ , $(V_A - V_B) \geq -50mV$	$V_{CC} - 0.4$			V
RO Output Logic-Low Voltage	$V_{OL}$	$I_{SINK} = 3mA$ , $(V_A - V_B) \leq -200mV$			0.4	V
RO Short-Circuit Current	$I_{IOSR}$	$0 \leq (V_A - V_B) \leq V_{CC}$	$V_{CC} = V_{CCL}$	90		mA
			$V_{CC} = V_{CCH}$	190		
<b>LOGIC INPUTS (DE, DI, POL)</b>						
Input Logic-High Voltage	$V_{IH}$		2			V
Input Logic-Low Voltage	$V_{IL}$				0.8	V
Input Hysteresis	$V_{HYS}$			100		mV
Input Leakage Current	$I_{IN}$	After first transition of DE	-1		+1	$\mu A$
DE Input Impedance on First Transition	$R_{IN\_FT}$		1		10	k $\Omega$

**Electrical Characteristics (continued)**

( $V_{CC} = 3.0V$  to  $3.6V$  and  $V_{CC} = 4.5V$  to  $5.5V$ ,  $T_A = T_{MIN}$  to  $T_{MAX}$ , unless otherwise noted. Typical values are at  $V_{CC} = 5.0V$  and  $T_A = +25^\circ C$ . POL = 0V (Note 1))

PARAMETER	SYMBOL	CONDITIONS	MIN	TYP	MAX	UNITS
<b>PROTECTION</b>						
Thermal Shutdown Threshold	$T_{SHDN}$	Temperature rising		+160		$^\circ C$
Thermal Shutdown Hysteresis	$T_{HYST}$			12		$^\circ C$
ESD Protection (A, B Pins to GND)		Human Body Model (JEDEC JS-001-2017)		$\pm 40$		kV
		IEC 61000-4-2 Contact Discharge		$\pm 10$		
		IEC 61000-4-2 Air Gap		$\pm 15$		
ESD Protection (All Other Pins)		Human Body Model		$\pm 4000$		V
		Charge Device Model		$\pm 2000$		
Fault Protection Range (A, B Pins to GND)		A, B independently or simultaneously	-65		+65	V
		A and B opposite polarity from separate supplies simultaneously	-65		+65	
<b>SWITCHING / DRIVER (NOTE 4) (NOTE 5)</b>						
Driver Propagation Delay	$t_{DPLH}, t_{DPHL}$	$R_L = 54\Omega, C_L = 50pF$ (Figure 2) (Figure 3)		50	1000	ns
Differential Driver Output Skew $ t_{DPLH} - t_{DPHL} $	$t_{DSKEW}$	$R_L = 54\Omega, C_L = 50pF$ (Figure 2) (Figure 3)		10	140	ns
Driver Differential Output Rise or Fall Time	$t_{LH}, t_{HL}$	$R_L = 54\Omega, C_L = 50pF$ (Figure 2) (Figure 3)		30	600	ns
Maximum Data Rate	$DR_{MAX}$	$R_L = 54\Omega, C_L = 50pF$	0.5			Mbps
Driver Enable to Output High or Output Low	$t_{DZH}, t_{DZL}$	$R_L = 110\Omega, C_L = 50pF$ (Figure 4) (Figure 5)		500		ns
Driver Enable Time	$t_D$	$-40V \leq V_{CM} \leq +40V$ , Figure 1b		3.5		$\mu s$
Driver Disable Time from Output Low or Output High	$t_{DLZ}, t_{DHZ}$	$R_L = 110\Omega, C_L = 50pF$ (Figure 4) (Figure 5)		500		ns
<b>SWITCHING / RECEIVER (Note 4) (Note 5)</b>						
Receiver Propagation Delay	$t_{RPLH}, t_{RPHL}$	$C_L = 15pF$ (Figure 6) (Figure 7)		130	200	ns
Receiver Output Skew	$t_{RSKEW}$	$C_L = 15pF$ (Figure 6) (Figure 7)		2	30	ns

**Note 1:** All devices are 100% production tested at  $T_A = +25^\circ C$ . Specifications over temperature are guaranteed by design.

**Note 2:**  $\Delta V_{OD}$  and  $\Delta V_{OC}$  are the changes in  $V_{OD}$  and  $V_{OC}$ , respectively, when DI changes state

**Note 3:** The short-circuit current is 450mA (max) for a short period (30 $\mu s$ , typ). If the short circuit persists, the outputs are then set to high impedance for 300ms (typ).

**Note 4:** Capacitive load includes test probe and fixture capacitance.

**Note 5:** Guaranteed by design. Not production tested.



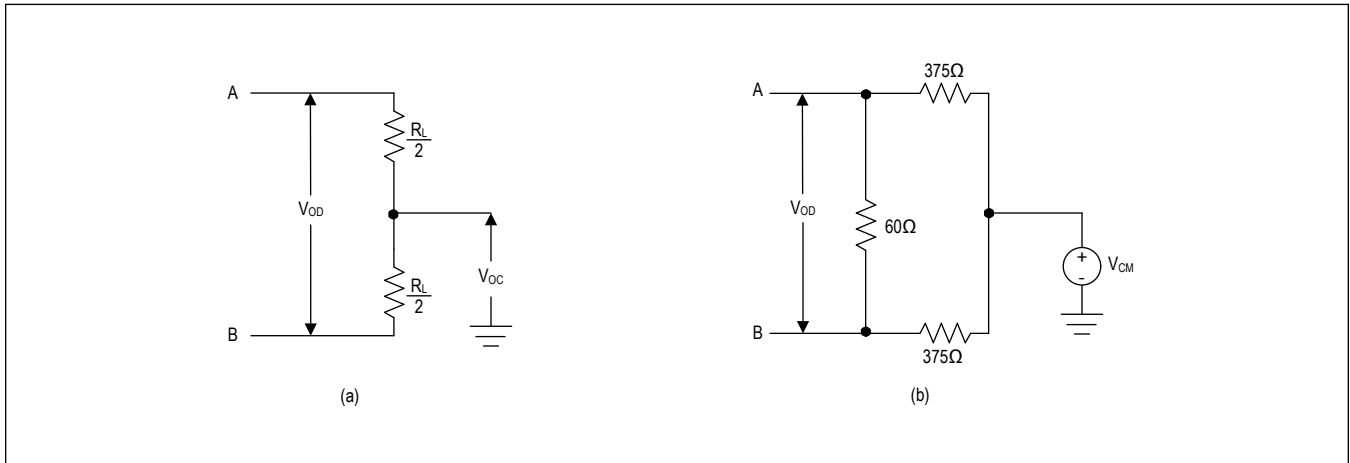

Figure 1. Driver DC Test Load

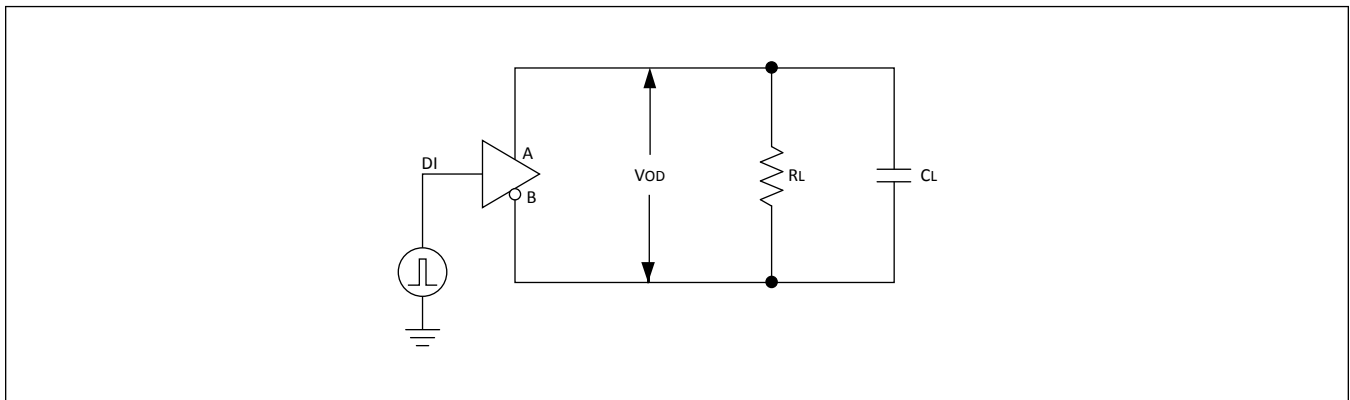

Figure 2. Driver Timer Test Circuit

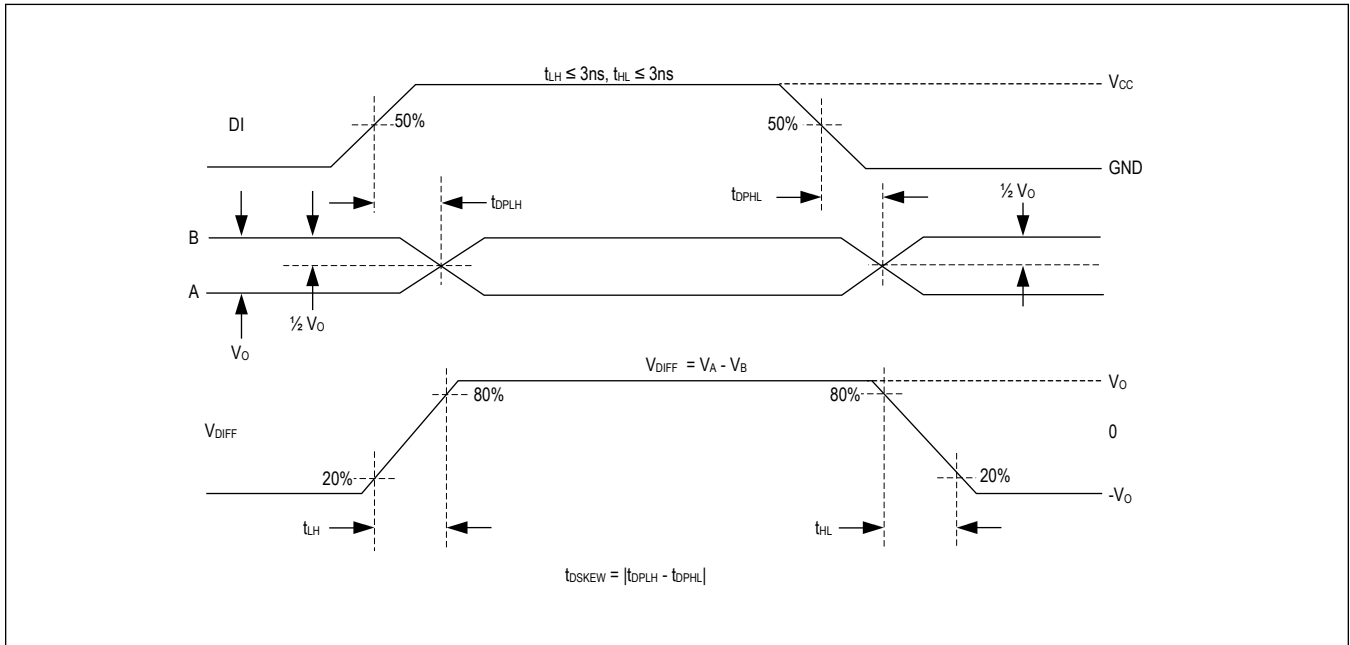

Figure 3. Driver Propagation Delays

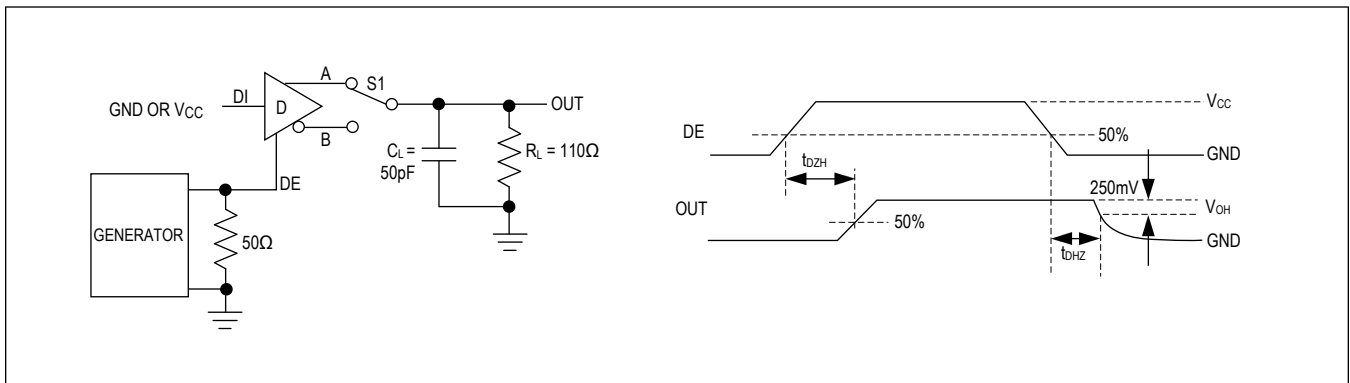

Figure 4. Driver Enable and Disable Times ( $t_{DZH}$ ,  $t_{DHZ}$ )

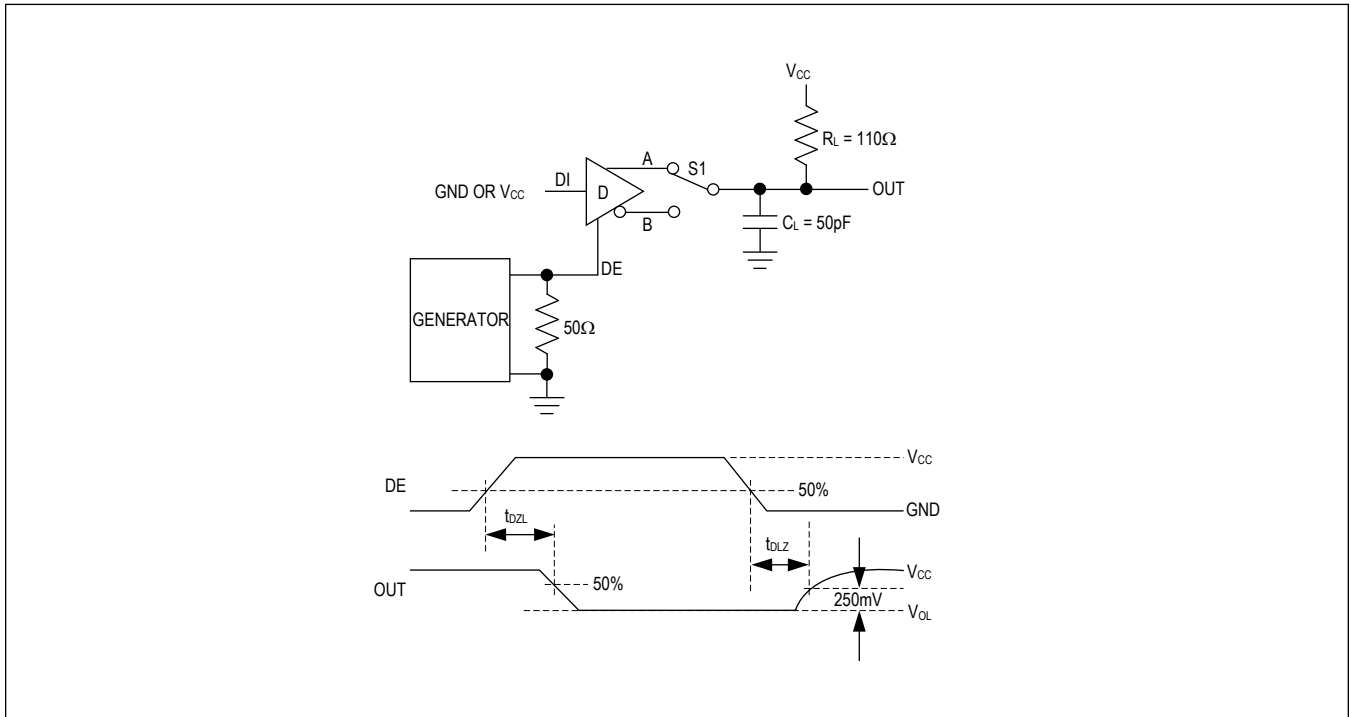

Figure 5. Driver Enable and Disable Times ( $t_{DZL}$ ,  $t_{DLZ}$ )

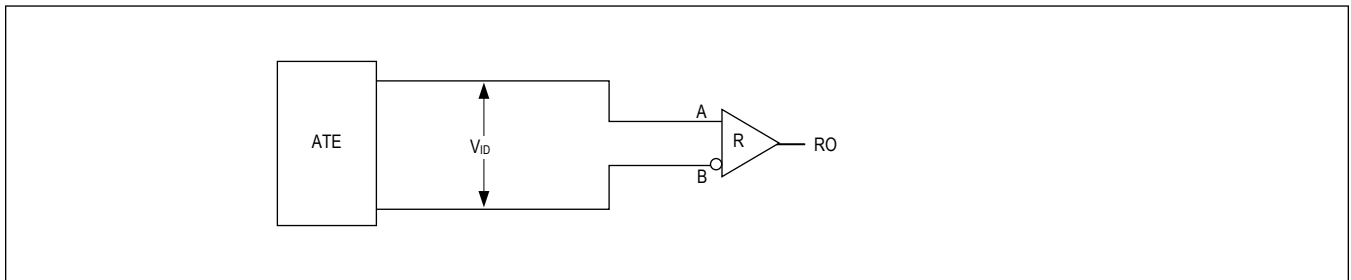

Figure 6. Receiver Propagation Delay Test Circuit

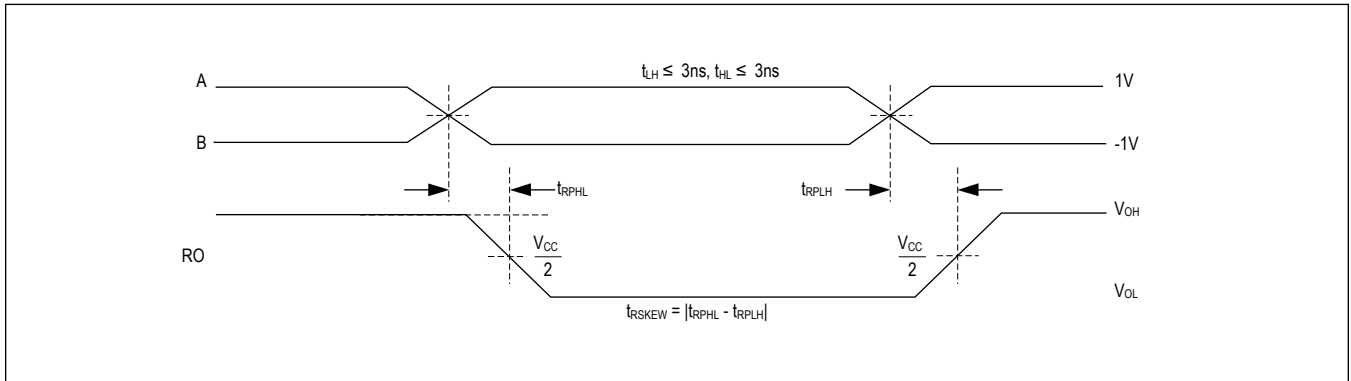
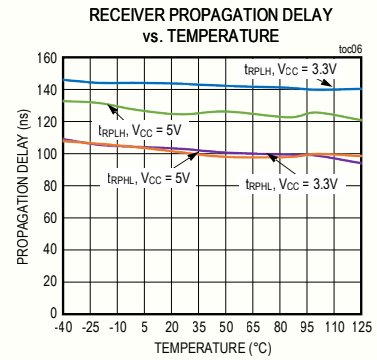
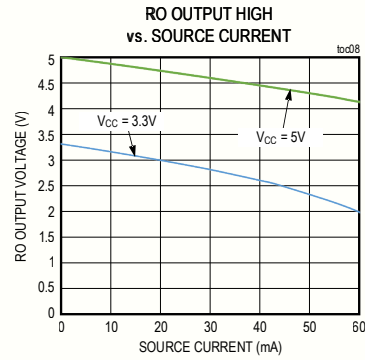
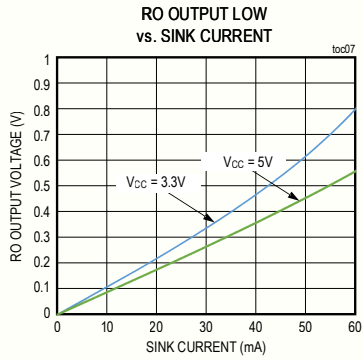
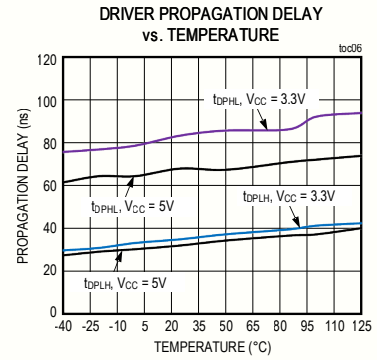
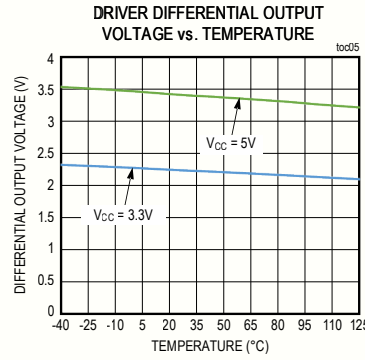
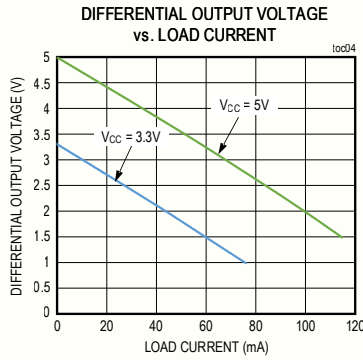
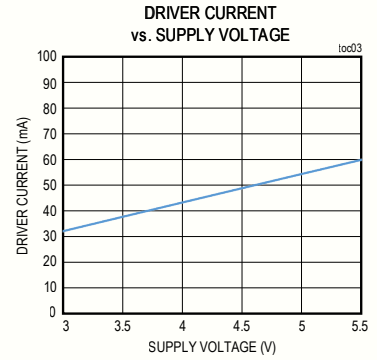
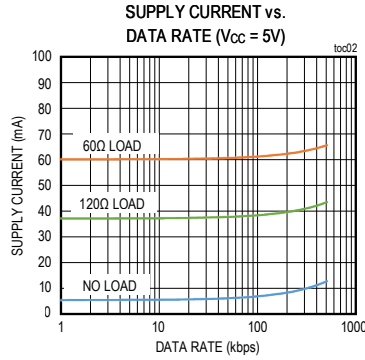
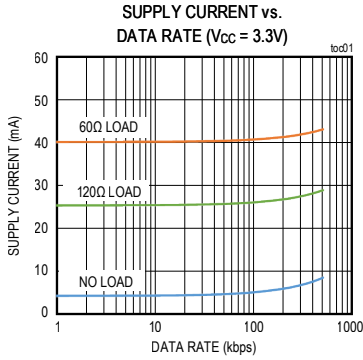

Figure 7. Receiver Propagation Delays

Typical Operating Characteristics

( $V_{CC} = 5V$ ,  $T_A = +25^\circ C$ , unless otherwise noted.)



MAX33072E/MAX33073E

+3V to +5.5V, Polarity Invert RS-485 Half-Duplex Transceiver with ±65V Fault Protection, ±40V CMR, and ±40kV ESD

### Typical Operating Characteristics (continued)

(V<sub>CC</sub> = 5V, T<sub>A</sub> = +25°C, unless otherwise noted.)

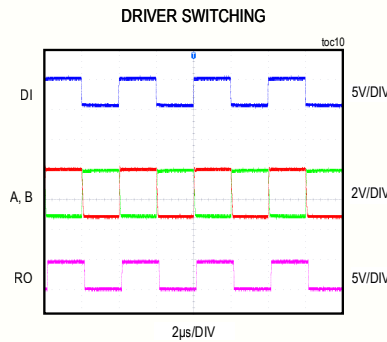

### Pin Configuration

#### SOIC

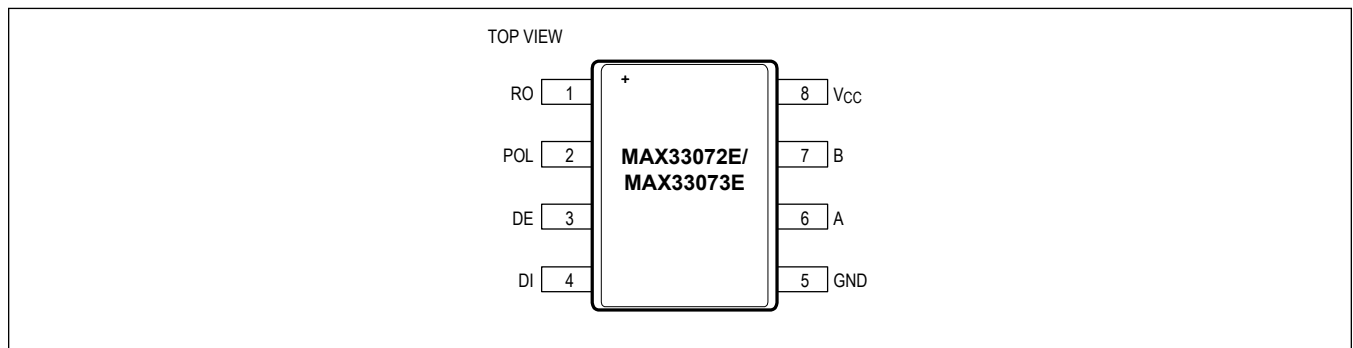

### Pin Description

PIN	NAME	FUNCTION
1	RO	Receiver Data Output. See Receiver Truth Table for more information.
2	POL	Polarity Select Input. Drive POL low for normal A/B operation. Drive POL high to switch A/B operation.
3	DE	Driver Output Enable. Drive DE high to enable the driver. Drive DE low or connect to GND to disable the driver. Receiver is always enabled.
4	DI	Driver Input. See Transmitter Truth Table for more information.
5	GND	Ground
6	A	Noninverting Driver Output/Receiver Input.
7	B	Inverting Driver Output/Receiver Input.
8	V <sub>CC</sub>	Power Supply Input. Bypass V <sub>CC</sub> to GND with a 0.1µF capacitor as close as possible to the device.

**MAX33072E/MAX33073E +3V to +5.5V, Polarity Invert RS-485 Half-Duplex Transceiver with ±65V Fault Protection, ±40V CMR, and ±40kV ESD**

**Detailed Description**

The MAX33072E/MAX33073E half-duplex transceivers are optimized for RS-485/RS-422 applications that require ±65V protection from faults on communication bus lines. These devices contain one differential driver and one differential receiver. The devices feature a polarity phase reversal pin which enables a software controlled method of correcting mis-wired A/B data lines. These devices feature a 1/8 unit load, allowing up to 256 transceivers on a single bus.

The MAX33072E supports a data rate up to 500kbps and the MAX33073E supports a data rate up to 2Mbps.

**Driver**

The driver accepts a single-ended, logic-level input (DI) and transfers it to a differential RS-485 level output on the A and B driver outputs. Set the driver enable input (DE) low to disable the driver. A and B are high impedance when the driver is disabled.

**Table 1. Transmitter Truth Table**

POL	DE	DI	A	B
0	1	0	0	1
0	1	1	1	0
1	1	0	1	0
1	1	1	0	1
X	0	X	High-Z	High-Z

**Receiver**

The receiver accepts a differential, RS-485 level on the A and B inputs and transfers it to a single-ended, logic-level output (RO). The receiver is always enabled, except during thermal shutdown. The state of the DE pin has no effect on the receiver.

**Table 2. Receiver Truth Table**

POL	(V <sub>A</sub> - V <sub>B</sub> )	RO
0	≥ -50mV	1
0	≤ -200mV	0
1	≤ 50mV	1
1	≥ 200mV	0
X	Open/Shorted	1

**±65V Fault Protection**

The driver outputs/receiver inputs of transceivers connected to an industrial RS-485 network often experience faults when shorted to voltages that exceed the -7V to +12V input range specified in the EIA/TIA-485 standard. Under such circumstances, ordinary RS-485 transceivers that have a typical absolute maximum voltage rating of -8V to +12.5V require costly external protection devices which can compromise the RS-485 performance.

To reduce system complexity and the need for external protection, the driver outputs/receiver inputs of the MAX33072E/MAX33073E are designed to withstand voltage faults of up to ±65V with respect to ground without damage. Protection is guaranteed regardless whether the transceiver is active, in shutdown or without power. When a fault is detected on A or B, the affected driver output is switched into a high-impedance state. After 300ms (typ), the driver output is re-enabled for 30µs (typ). If the fault condition persists, the driver output is again disabled. If the fault has been removed, the driver outputs remain on and the transceiver operates normally.

Driving a non-terminated cable may cause the voltage seen at the driver outputs (A or B) to exceed the absolute maximum voltage rating if the DI input is switched during a ±65V fault on the A or B pins. Therefore, a termination resistor

---

## MAX33072E/MAX33073E +3V to +5.5V, Polarity Invert RS-485 Half-Duplex Transceiver with $\pm 65\text{V}$ Fault Protection, $\pm 40\text{V}$ CMR, and $\pm 40\text{kV}$ ESD

is recommended in order to maximize the overvoltage fault protection while the DI input is being switched. If the DI input does not change state while the fault condition is present, the MAX33072E/MAX33073E will withstand up to  $\pm 65\text{V}$  on the RS-485 inputs, regardless of the termination status of the data cable.

### **$\pm 40\text{V}$ Common-Mode Range**

RS-485 standards define the common-mode range as  $-7\text{V}$  to  $+12\text{V}$  for the receiver. For the MAX33072E and MAX33073E, the common-mode range exceeds the standard with  $\pm 40\text{V}$  for both the driver and receiver. This feature was specifically designed for systems where there is a large common-mode voltage present due to either nearby electrically noisy equipment or large ground differences due to different earth grounds or different power transformers. Two-way communication is possible with  $\pm 40\text{V}$  high common-mode range where other standard RS-485 transceivers would either fail, not transmit or receive, and/or cause data errors.

### **True Fail-Safe**

The MAX33072E/MAX33073E guarantees a logic-high receiver output when the receiver inputs are shorted or open, or when they are connected to a terminated transmission line with all drivers disabled. If the differential receiver input voltage ( $V_A - V_B$ ) is greater than or equal to  $-50\text{mV}$ , RO is logic-high when POL is logic-low.

### **Hot-Swap Inputs**

Inserting circuit boards into a hot, or powered backplane may cause voltage transients on DE, and receiver inputs A and B that can lead to data errors. For example, upon initial circuit board insertion, the processor undergoes a power-up sequence. During this period, the high impedance state of the output drivers makes them unable to drive the MAX33072E/MAX33073E DE input to a defined logic level. Meanwhile, leakage currents of up to  $10\mu\text{A}$  from the high-impedance output, or capacitively coupled noise from  $V_{CC}$  or GND, could cause an input to drift to an incorrect logic state. To prevent such a condition from occurring, the MAX33072E/MAX33073E features hot-swap input circuitry on DE to safeguard against unwanted driver activation during hot-swap situations. When  $V_{CC}$  rises, an internal pulldown circuit holds DE low for at least  $10\mu\text{s}$ . After the first transition on DE, the internal pulldown/pullup circuitry becomes transparent, resetting the hot-swap tolerable inputs.

### **Thermal Shutdown Protection**

The MAX33072E/MAX33073E feature thermal-shutdown protection circuitry to protect the device. When the internal silicon junction temperature exceeds  $+160^\circ\text{C}$  (typ), the driver outputs are disabled and RO is high impedance. Driver and receiver outputs are re-enabled when the junction temperature falls below  $+148^\circ\text{C}$  (typ).



MAX33072E/MAX33073E +3V to +5.5V, Polarity Invert RS-485 Half-Duplex Transceiver with ±65V Fault Protection, ±40V CMR, and ±40kV ESD

## Applications Information

### 256 Transceivers on the Bus

The MAX33072E/MAX33073E transceivers have 1/8 unit load receiver, allowing for up to 256 MAX33072E/MAX33073E transceivers connected in parallel on a shared communication line. Connect any combination of these devices, and/or other RS-485 devices, for a maximum of 32 unit loads on the line.

### Typical Application

The MAX33072E/MAX33073E half-duplex transceivers are designed for bidirectional data communications on multipoint bus transmission lines. The Typical Application Circuit shows a typical network application's circuit. To minimize reflections, the bus should be terminated at the receiver inputs in its characteristic impedance, and stub lengths off the main line should be kept as short as possible.

### Power Considerations for the MAX33072E/MAX33073E

At high data rates, the power dissipation of a half-duplex transceiver is determined by a number of factors, including:

- The data rate
- The time that the driver is transmitting
- The termination impedance
- The power supply voltage
- The external common-mode voltage

Higher data rates result in higher power dissipation due to switching losses in the transceiver. Switching losses increase even more when capacitance is applied to the A and B pins. External capacitance should be kept to a minimum to help reduce power dissipations at high data rates.

Similarly, the power dissipation in a transceiver is much higher when the driver is transmitting, compared to when the transceiver is receiving. In half-duplex communication, the period of transmission relative to the idle or receiving intervals (i.e., the duty cycle) should be taken into consideration when calculating the average power dissipation.

The line termination resistance/impedance determines the driver's load current during transmission and the differential output voltage ( $V_{OD}$ ) on the driver is determined by the supply voltage. A higher supply voltage results in a larger differential output voltage at the driver driving the line, which in turn results in a higher current draw from the supply ( $I_{CC}$ ).

The power dissipation in the chip is calculated as the product of supply current times supply voltage, subtracting the power dissipated in the external termination resistor. If there is a common-mode voltage (higher than  $V_{CC}$ ) present (Figure 1b), the transceiver will pull this voltage down to operating levels by sinking current into the A pin (or B pin, whichever is lower). This is factored into the following equation:

$$P_{DIS} = (V_{CC} \times I_{CC}) - (V_{OD}^2/R_L) + (V_{AB} \times I_{AB})$$

where  $I_{AB} = ((V_{CM} - V_{AB})/375) + ((V_{CC} - V_{AB})/R_L)$ .

Use the Typical Operation Characteristics to determine the supply current at a given supply voltage and data rate.

For example, assuming a data rate of 500kbps with a 5V supply on a fully loaded bus with +40V common mode (Figure 1b), and assuming  $V_{AB} = 1.5V$  (the lower of A, B), we can calculate that the power dissipation (at room temperature) is:

$$P_{DIS} = (5V \times 65mA) - (3.4V^2/60\Omega) + (1.5V \times 160mA) = 564mW$$

Ensure that power dissipation of the transceiver is kept below the value listed in the [Absolute Maximum Ratings](#) to protect the device from entering thermal shutdown or from damage.

### PCB Layout Considerations

PCB layout can affect the performance of the transceiver in conditions with high common-mode voltage at a high ambient temperature. In order to maximize thermal dissipation, it is recommended to:

1. Use large copper pads for all the pins.
2. Connect the GND pad to a large copper plane on the same layer or through vias to the bottom layer.

### ESD Protection

ESD protection structures are incorporated on all pins to protect against electrostatic discharge encountered during handling and assembly. The driver outputs and receiver inputs (A and B data lines) of the MAX33072E/MAX33073E have extra protection against static electricity. The ESD structures withstand high ESD in normal operation and when powered down. After an ESD event, the devices keep working without latch-up or damage.

ESD protection can be tested in various ways. The transmitter outputs and receiver inputs (A and B data lines) of the devices are characterized for protection to the cable-side ground (GNDB) to the following limits:

- $\pm 40\text{kV}$  Human Body Model (HBM) per JEDEC JS-001-2017
- $\pm 15\text{kV}$  using the Air Gap Discharge method specified in the IEC 61000-4-2
- $\pm 10\text{kV}$  using the Contact Discharge method specified in the IEC 61000-4-2

The other non-data pins are also ESD protected, but at a lower level per the [Electrical Characteristics](#) table.

### ESD Test Conditions

ESD performance depends on a variety of conditions. Contact Maxim for a reliability report that documents test setup, test methodology and test results.

### Human Body Model (HBM)

[Figure 8](#) shows the HBM test model and [Figure 9](#) shows the current waveform it generates when discharged in a low-impedance state. This model consists of a  $100\text{pF}$  capacitor charged to the ESD voltage of interest, which is then discharged into the test device through a  $1.5\text{k}\Omega$  resistor.

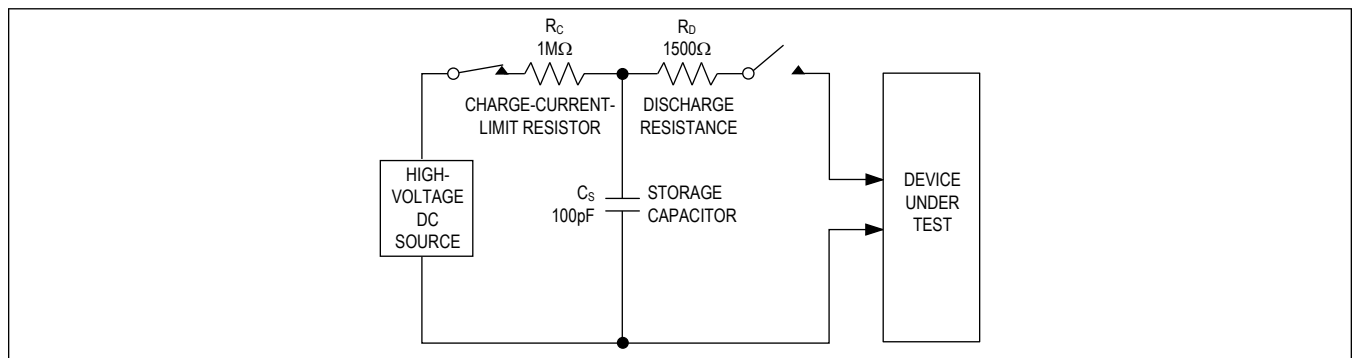

Figure 8. Human Body ESD Test Model

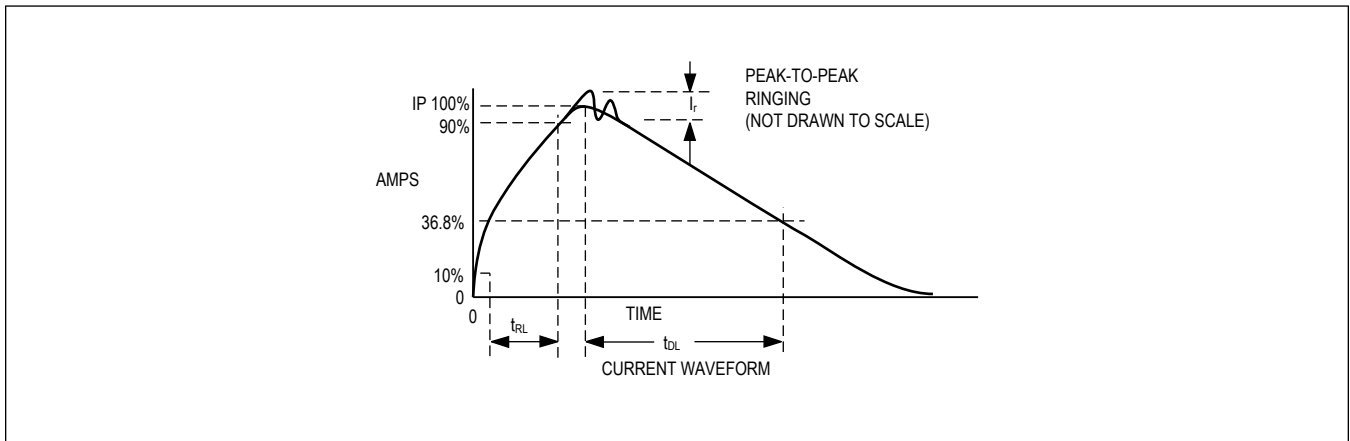

Figure 9. Human Body Current Waveform

**IEC 61000-4-2**

The IEC 61000-4-2 standard covers ESD testing and performance of finished equipment. However, it does not specifically refer to integrated circuits. The MAX33072E/MAX33073E help in designing equipment to meet IEC 61000-4-2 without the need for additional ESD protection components.

The major difference between tests done using the HBM and IEC 61000-4-2 is higher peak current in IEC 61000-4-2 because series resistance is lower in the IEC 61000-4-2 model. Hence, the ESD withstand voltage measured to IEC 61000-4-2 is generally lower than that measured using the HBM. [Figure 10](#) shows the IEC 61000-4-2 model and [Figure 11](#) shows the current waveform for IEC 61000-4-2 ESD Contact Discharge and Air Gap tests.

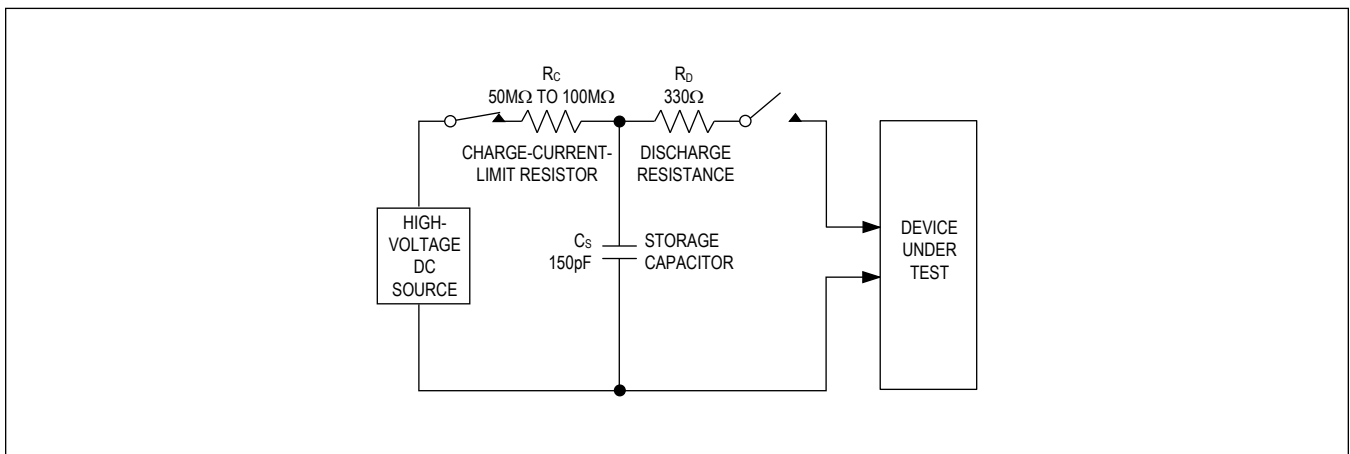

Figure 10. IEC 61000-4-2 ESD Test Model

MAX33072E/MAX33073E

+3V to +5.5V, Polarity Invert RS-485 Half-Duplex Transceiver with  $\pm 65V$  Fault Protection,  $\pm 40V$  CMR, and  $\pm 40kV$  ESD

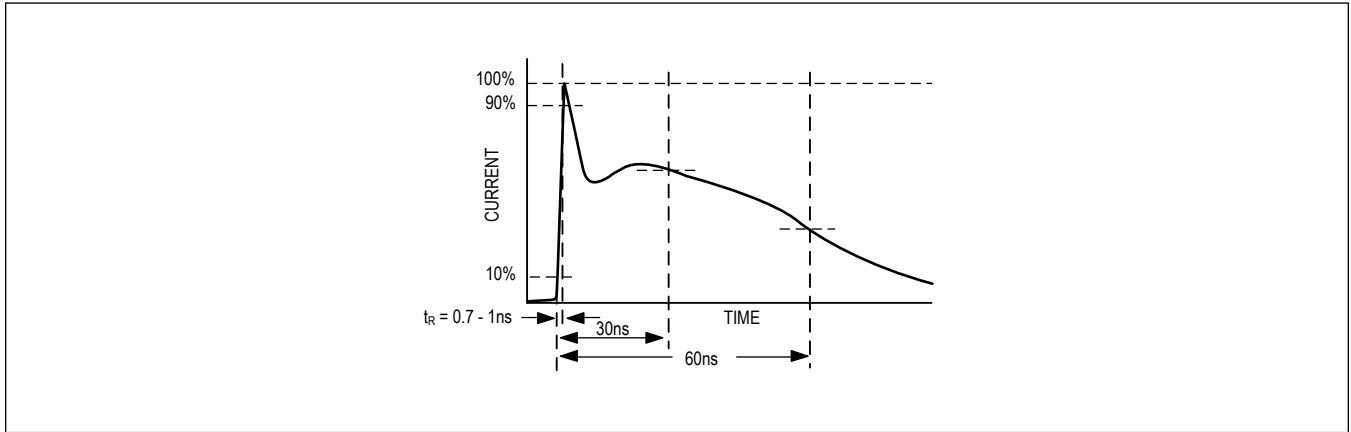
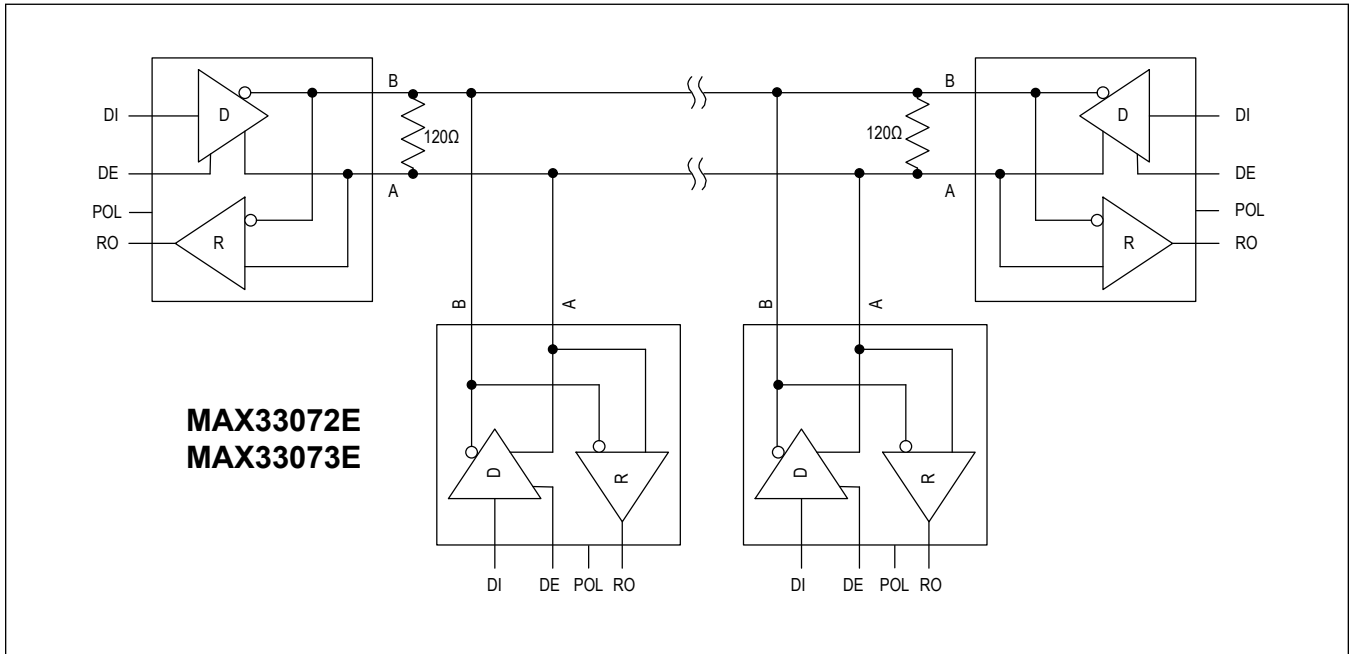

Figure 11. IEC 61000-4-2 ESD Generator Current Waveform

### Typical Application Circuit

#### Typical RS-485 Network



MAX33072E/MAX33073E +3V to +5.5V, Polarity Invert RS-485 Half-Duplex Transceiver with  $\pm 65\text{V}$  Fault Protection,  $\pm 40\text{V}$  CMR, and  $\pm 40\text{kV}$  ESD

### Ordering Information

PART NUMBER	TEMPERATURE RANGE	PIN-PACKAGE	MAXIMUM DATA RATE
MAX33072EASA+	-40°C to +125°C	8 SO	500kbps
MAX33072EASA+T	-40°C to +125°C	8 SO	500kbps
MAX33073EASA+*	-40°C to +125°C	8 SO	2Mbps
MAX33073EASA+T*	-40°C to +125°C	8 SO	2Mbps

+ = Denotes a lead(Pb)-free/RoHS-compliant package.

T = Tape and reel.

\*Future product—contact factory for availability.

MAX33072E/MAX33073E +3V to +5.5V, Polarity Invert RS-485 Half-Duplex Transceiver with  $\pm 65\text{V}$  Fault Protection,  $\pm 40\text{V}$  CMR, and  $\pm 40\text{kV}$  ESD

## Revision History

REVISION NUMBER	REVISION DATE	DESCRIPTION	PAGES CHANGED
0	3/20	Initial release	—

For pricing, delivery, and ordering information, please visit Maxim Integrated's online storefront at <https://www.maximintegrated.com/en/storefront/storefront.html>.

*Maxim Integrated cannot assume responsibility for use of any circuitry other than circuitry entirely embodied in a Maxim Integrated product. No circuit patent licenses are implied. Maxim Integrated reserves the right to change the circuitry and specifications without notice at any time. The parametric values (min and max limits) shown in the Electrical Characteristics table are guaranteed. Other parametric values quoted in this data sheet are provided for guidance.*