

General Description

The MAX17292 evaluation kit (EV kit) is a fully assembled and tested PCB that contains a 16W DC-DC boost converter for battery-operated, harsh environment, front-end preboost applications. The MAX17292 integrates a low-side FET driver and current-mode, control-loop circuitry for output-voltage regulation, making it ideal for boost or SEPIC converters. The MAX17292's integrated driver switches at 2.2MHz. The device can be synchronized with an external clock source within the 1MHz to 2.5MHz range.

The EV kit operates from a DC supply voltage of 3V up to 8V. The EV kit can withstand a 16V line transient condition. The EV kit demonstrates the device features, such as dynamic adjustable output voltage, external clock synchronization, two-phase operation configurability, cycle-by-cycle current limit, hiccup mode, and thermal shutdown. The boost converter regulates 8V and can supply a current up to 2A. The EV kit also demonstrates a reference MAX17292 design for battery-operated, harsh environment applications.

Features

- 3V Up to 8V Input Voltage Range
- 87% Peak Efficiency at 5V Input
- 8V up to 2A Output
- Demonstrates External Clock Synchronization
- Spread Spectrum Optimizes EMI Performance
- Demonstrates SUP UVLO
- Demonstrates Cycle-by-Cycle Current Limit and Hiccup Mode
- Thermal-Shutdown Protection
- PGOOD Flag
- Demonstrates Dynamic Adjustable Output
- Demonstrates 2.2MHz Single/Two-Phase Operation
- Compact 1240mil x 1040mil Overall Circuit Footprint Design (0.775 sq. in.)
- Proven 4-Layer 2oz. PCB Layout and Thermal Design
- Fully Assembled and Tested

Quick Start

Required Equipment

- MAX17292 EV kit
- 3V to 8V, 10A DC power supply
- Digital voltmeter (DVM)
- 2A load

Output Testing

This EV kit is fully assembled and tested. Follow the steps below to verify board operation. **Caution: Do not turn on the power supply until all connections are completed.**

- 1) Verify that a shunt is installed on pins 1-2 of jumper JU1 (device enabled).
- 2) Verify that a shunt is installed on pins 1-2 (normal mode) or 2-3 (bootstrapped mode) on jumper JU2.
- 3) Verify that a shunt is installed on jumper JU3 (internal 1V reference).
- 4) Connect the power supply's positive terminal to the V_{BAT} PCB banana jack and the power supply's ground to the PGND PCB banana jack.
- 5) Connect the load across the V_{OUT} and PGND banana jacks.
- 6) Connect the DVM across V_{OUT} and PGND.
- 7) Turn on the power supply and set it to 4.5V.
- 8) Measure V_{OUT} and verify that it is 8V.

[Ordering Information](#) appears at end of data sheet.

Detailed Description of Hardware

The MAX17292 EV kit is a fully assembled and tested 4-layer PCB that contains a 16W DC-DC boost converter for battery-operated, harsh environment applications, such as front-end, preboost power-supply applications. The EV kit demonstrates the device's features, such as the integrated low-side FET driver and current-mode control-loop circuitry for output-voltage regulation. The device's integrated driver switches at 2.2MHz and can be synchronized with an external clock source within the 1MHz to 2.5MHz range.

The EV kit operates from a DC supply voltage of 3V up to 8V. The EV kit can withstand a 16V line transient, that is limited by input capacitor C4 maximum voltage or U1 specific pin 16V rating, whichever is less. The EV kit demonstrates the device features such as dynamic adjustable output voltage, external clock synchronization, single/two-phase operation configurability, cycle-by-cycle current limit, hiccup mode, and thermal shutdown. The boost converter regulates 8V and can supply a current up to 2A.

Enable

The EV kit features an enable input and a jumper (JU1) that can be used to enable/disable the device and place it in shutdown mode. The EV kit is enabled whenever power is applied to V_{BAT} and PGND above 4.5V and EN is pulled high.

To enable the EV kit from an external enable signal, remove the shunt from JU1 and apply a logic signal on the EN and AGND test points of the EV kit. The enable (EN) input should not be left unconnected (see [Table 1](#) below). Refer to the EN pin description in the MAX17292 IC data sheet for additional information. See [Table 1](#) for EN settings.

Bootstrap Mode

For applications where the input voltage goes below 4.5V, use the device in bootstrapped mode by installing a shunt on pins 2-3 of jumper JU2. In bootstrapped configuration, the device is supplied by the output of the boost regulator itself and does not trigger the UVLO, even if the input voltage goes down to 3V. See [Table 2](#) for jumper JU2 settings.

Output-Voltage Adjustment

The V_{OUT} output voltage can be dynamically adjusted by feeding an analog voltage to the REFIN and AGND test points. The external voltage applied to REFIN is used as the FB reference. Remove the shunt on JU3 to apply an external voltage to REFIN. With the shunt installed on jumper JU3, REFIN is shorted to PVL and an internal 1V FB reference is used for loop regulation. The output voltage can be adjusted in the range of 4V to 16V. See [Table 3](#) for jumper JU3 settings.

External Clock Synchronization

The MAX17292 IC can be synchronized using an external clock applied to the FSET/SYNC and AGND test points. A falling clock edge on FSET/SYNC turns on the external MOSFET by driving DRV high after a short delay. The MAX17292 can be synchronized with an external clock source within the 1MHz to 2.5MHz range, and a logic-high voltage range of 2.5V to 5V.

Table 1. Enable (JU1)

SHUNT POSITION	EN PIN	EV KIT OPERATION
Installed*	Connected to V_{BAT}	Enabled
Installed	Connected to AGND	Disabled
Removed	Connected to an external controller	External controller enabled

*Default position.

Table 2. Bootstrap Mode (JU2)

SHUNT POSITION	SUP PIN	EV KIT OPERATION
1-2*	Connected to V_{BAT}	Normal
2-3	Connected to V_{OUT}	Bootstrapped

*Default position.

Two-Phase Configuration

To configure the EV kit for two-phase operation, use two EV kits and follow the instructions below:

Master EV kit:

- 1) Install a 0603 surface-mount 1kΩ resistor on the R8 pads.

Slave EV kit:

- 1) Remove resistors R2 and R1.
- 2) Remove capacitors C2, C3, and resistor R5.
- 3) Install a 0603 surface mount 0Ω resistor on R11 pads.

Make the following connections:

- 1) Connect the PGND banana jack on the master to the PGND banana jack on the slave.
- 2) Connect the AGND test point on the master to the AGND test point on the slave.
- 3) Connect the V_{BAT} banana jack on the master to the V_{BAT} banana jack on the slave.
- 4) Connect the V_{OUT} banana jack on the master to the V_{OUT} banana jack on the slave.
- 5) Connect the COMP PCB pin on the master to the COMP pin on the slave through a SMA cable.
- 6) Connect the SYNCO test point on the master to the FSET/SYNC test point on the slave.

Table 3. Output Voltage Adjustment (JU3)

SHUNT POSITION	SUP PIN	EV KIT OPERATION
1-2*	Connected to V _{BAT}	Normal
2-3	Connected to V _{OUT}	Bootstrapped

*Default position.

Component Suppliers

SUPPLIER	WEBSITE
Fairchild Semiconductor	www.fairchildsemi.com
Kemet	www.kemet.com
Murata Americas	www.murata.com
NXP	www.nxp.com
Panasonic Corp.	www.panasonic.com
Würth Elektronik GmbH	www.we-online.com

Note: Indicate that you are using the MAX17292 when contacting these component suppliers.

MAX17292 EV Bill of Materials

Reference Designators	Qty	Description
AGND	1	TEST POINT; PIN DIA=0.1IN; TOTAL LENGTH=0.3IN; BOARD HOLE=0.04IN; BLACK; PHOSPHOR BRONZE WIRE SILVER PLATE FINISH
EN, FB, FSET/ SYNC, PGOOD, PVL, REFIN, SYNCO	7	TEST POINT; PIN DIA=0.1IN; TOTAL LENGTH=0.3IN; BOARD HOLE=0.04IN; RED; PHOSPHOR BRONZE WIRE SILVER PLATE FINISH
C1	1	CAPACITOR; SMT; (1210); CERAMIC CHIP; 47UF; 16V; TOL=10%; MODEL=GRM SERIES; TG=-55 DEGC TO +85 DEGC; TC=X5R
C2	1	CAPACITOR; SMT; (0603); CERAMIC; 6200pF; 50V; ±5%; C0G, NP0; -55degC to + 125degC.
C3	1	CAPACITOR; SMT; (0603); CERAMIC; 150pF; 50V; ±5%; C0G, NP0; -55degC to + 125degC.
C4	1	CAPACITOR; SMT; (SMD); ALUMINUM-ELECTROLYTIC; 47UF; 50V; TOL=20%
C5, C11	2	CAPACITOR; SMT; (0805); CERAMIC CHIP; 1UF; 50V; TOL=10%; TG=-55 DEGC TO +125 DEGC; TC=X7R
C6	1	CAPACITOR; SMT; (0603); CERAMIC CHIP; 2.2UF; 10V; TOL=10%; TG=-55 DEGC TO +125 DEGC; TC=X7R;
C12	1	CAPACITOR; SMT; (0402); CERAMIC CHIP; 0.1UF; 16V; TOL=10%; TG=-55 DEGC TO +125 DEGC; TC=X7R;
COMP	1	CONNECTOR; FEMALE THREADED; THROUGH HOLE; SMA; STRAIGHT THROUGH; 5PINS
D1	1	DIODE; SCH; SMT; (SOT-1289); PIV=45V; IF=15A
JU1, JU2	2	CONNECTOR; MALE; THROUGH HOLE; BREAKAWAY; STRAIGHT; 3PINS
JU3	1	CONNECTOR; MALE; THROUGH HOLE; BREAKAWAY; STRAIGHT; 2PINS
L1	1	0.47uH, 18A inductor (7mm x 6.9mm)
N1	1	TRAN; N-CHANNEL POWERTRENCH MOSFET; NCH; SO-8; PD-(2.5W); I-(10A); V-(60V)
R1	1	RESISTOR; 0402; 90.9 KOHM; 1%; 100PPM; 0.10W; METAL FILM
R2	1	RESISTOR; 0402; 13.0 KOHM; 1%; 100PPM; 0.10W; METAL FILM
R3	1	RESISTOR; 1812; 0.022 OHM; 1%; 300PPM; 0.5W; THICK FILM
R4	1	RESISTOR; 0402; 1 KOHM; 1%
R5	1	RESISTOR; 0402; 6.81 KOHM; 1%
R6	1	RESISTOR; 0402; 10 KOHM; 5%
R7	1	RESISTOR; 0402; 12.1 KOHM; 1%
R9	1	RESISTOR; 0402; 0 OHM; 0%; JUMPER; 0.10W; THICK FILM
PGND (2x), VOUT, SUP	4	CONNECTOR; MALE; PANELMOUNT; BANANA JACK; STRAIGHT; 1PIN
U1	1	EVKIT PART-IC; MAX17292; PACKAGE OUTLINE: 21-0136; PACKAGE CODE: T1233-4; TQFN12-EP
C7	0	PACKAGE OUTLINE 1210 NON-POLAR CAPACITOR
C8	0	PACKAGE OUTLINE 0402 NON-POLAR CAPACITOR
C9, C10	0	PACKAGE OUTLINE 0603 NON-POLAR CAPACITOR
R8, R11	0	PACKAGE OUTLINE 0402 RESISTOR
R14, R15	0	PACKAGE OUTLINE 0603 RESISTOR
PCB	1	PCB Board:MAX17292 EVALUATION KIT

MAX17292 EV PCB Layout Diagrams

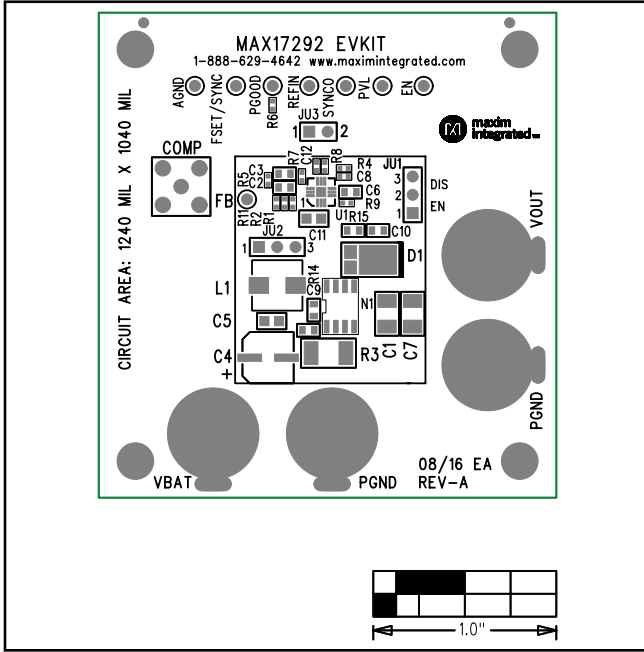

MAX17292 EV Kit—Top Silkscreen

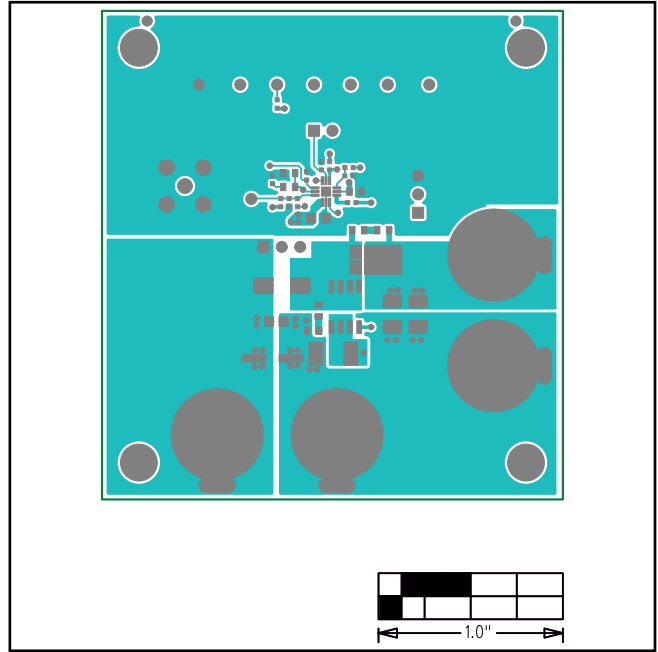

MAX17292 EV Kit—Component Side

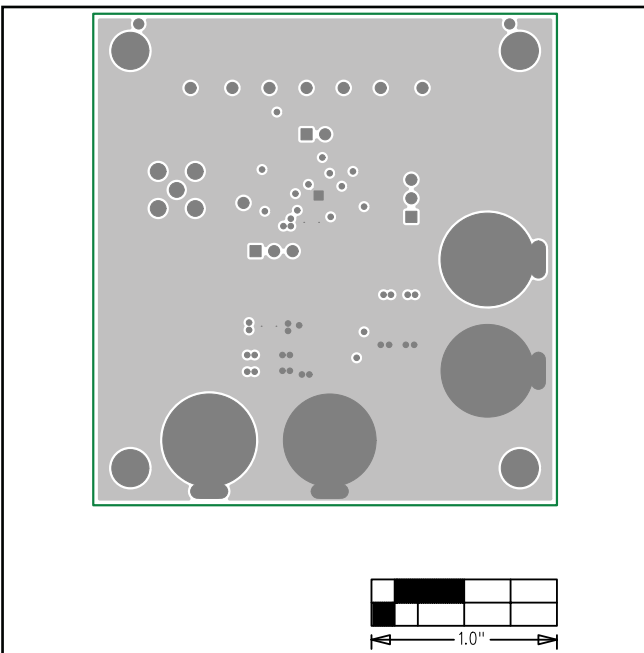

MAX17292 EV Kit—Layer 2 GND

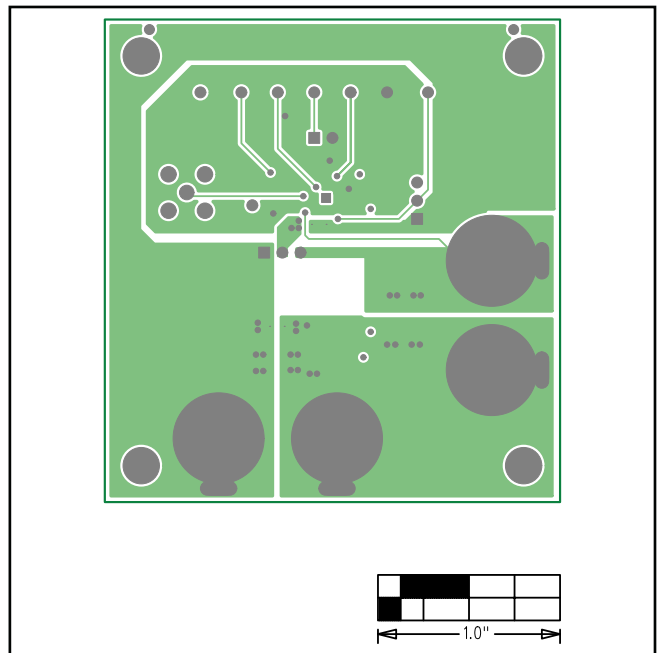

MAX17292 EV Kit—Layer 3

MAX17292 EV PCB Layout Diagrams (continued)

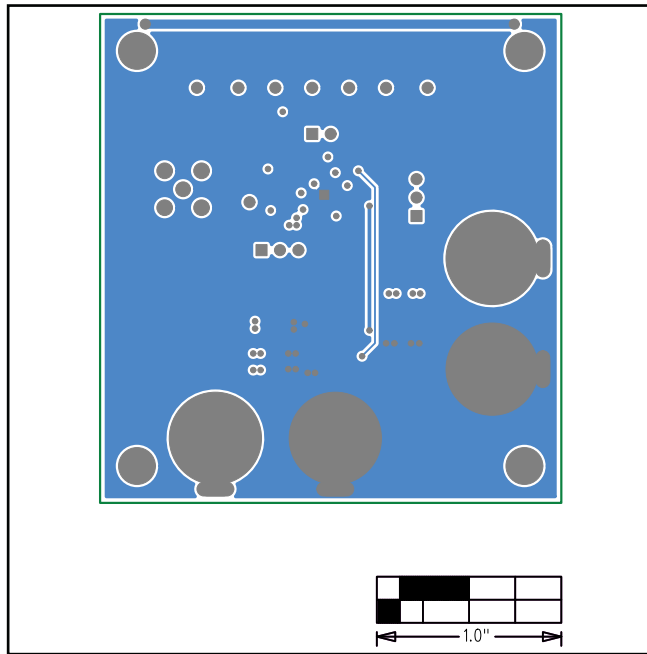

MAX17292 EV Kit—Solder Side

MAX17292 EV Minimal Component Schematic

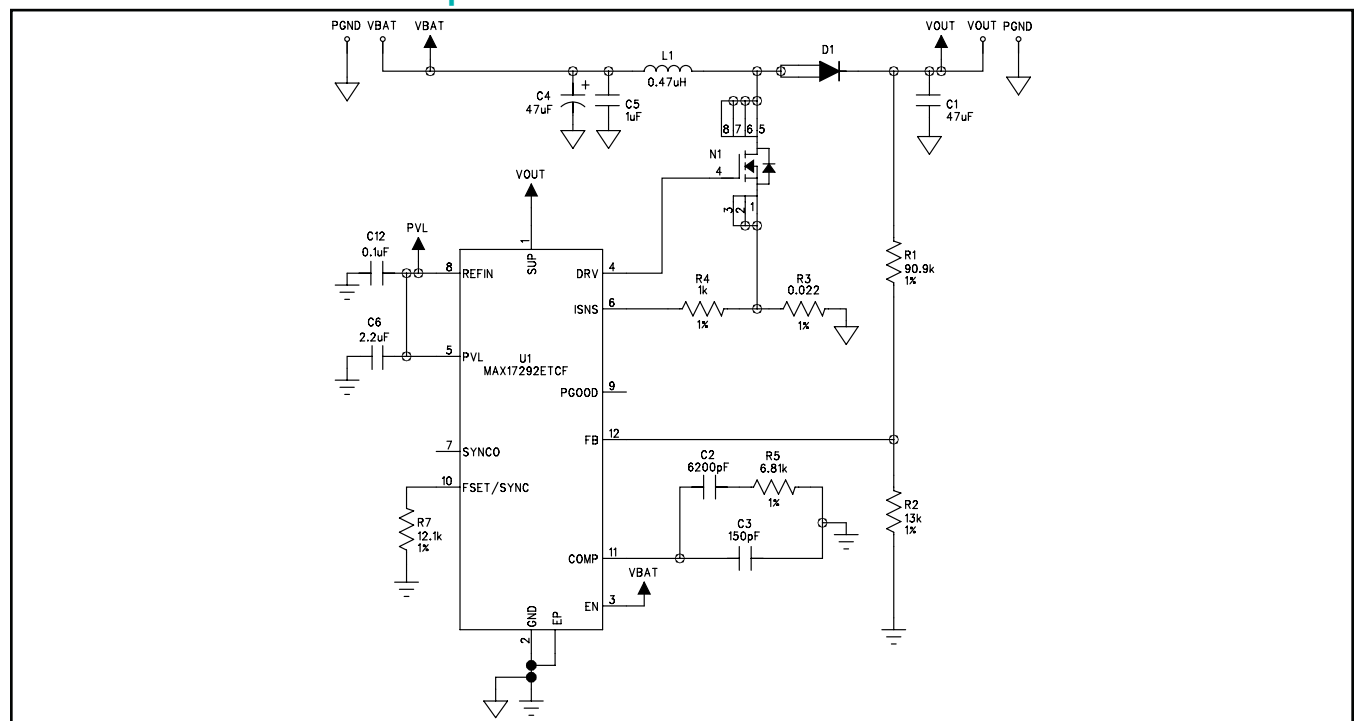

MAX17292 EV Schematic

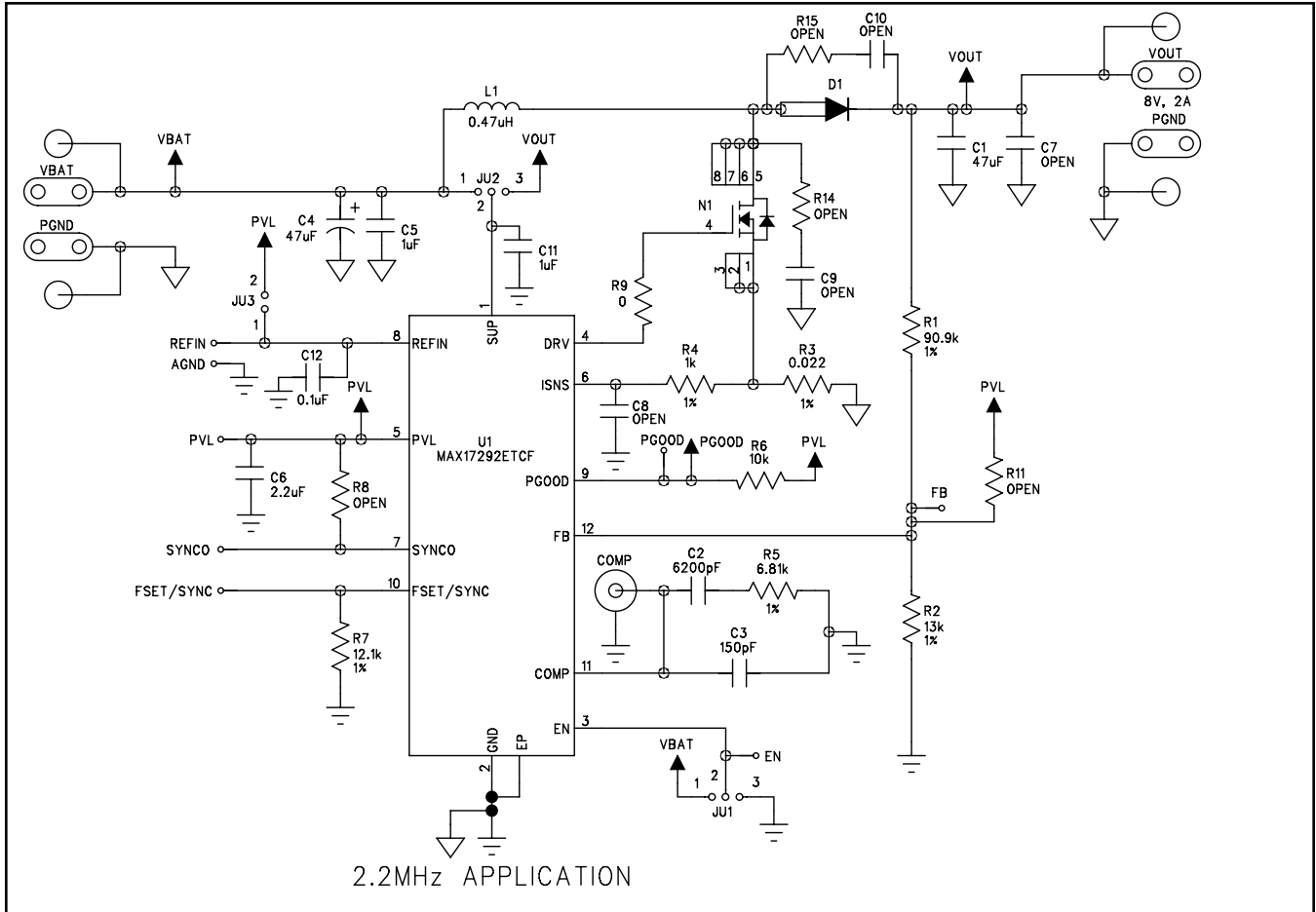

Ordering Information

PART	TYPE
MAX17292EVKIT#	EV Kit

#Denotes RoHS compliant.

Revision History

REVISION NUMBER	REVISION DATE	DESCRIPTION	PAGES CHANGED
0	9/16	Initial release	—

For pricing, delivery, and ordering information, please contact Maxim Direct at 1-888-629-4642, or visit Maxim Integrated's website at www.maximintegrated.com.

Maxim Integrated cannot assume responsibility for use of any circuitry other than circuitry entirely embodied in a Maxim Integrated product. No circuit patent licenses are implied. Maxim Integrated reserves the right to change the circuitry and specifications without notice at any time.