

General Description

The DS1088E is a low-cost clock generator that produces a square-wave output without external timing components. The fixed-frequency oscillator is available in a factory-calibrated frequency of 133MHz. The device has a power-down pin for power-sensitive applications.

Applications

- Optical Modules
- Printers
- Copiers
- Automotive Telematics
- Computer Peripherals
- POS Terminals
- Cable Modems

Benefits and Features

- Factory-Programmed, 133MHz Square-Wave Generator
- Single Output
- No External Timing Components Required
- 2.85V to 3.6V Supply
- Power-Down Mode
- Wide Temperature Range (-40°C to +95°C)

EconOscillator is a trademark of Maxim Integrated Products, Inc.

Ordering Information appears at end of data sheet.

For related parts and recommended products to use with this part, refer to www.maximintegrated.com/DS1088E.related.

Typical Operating Circuit

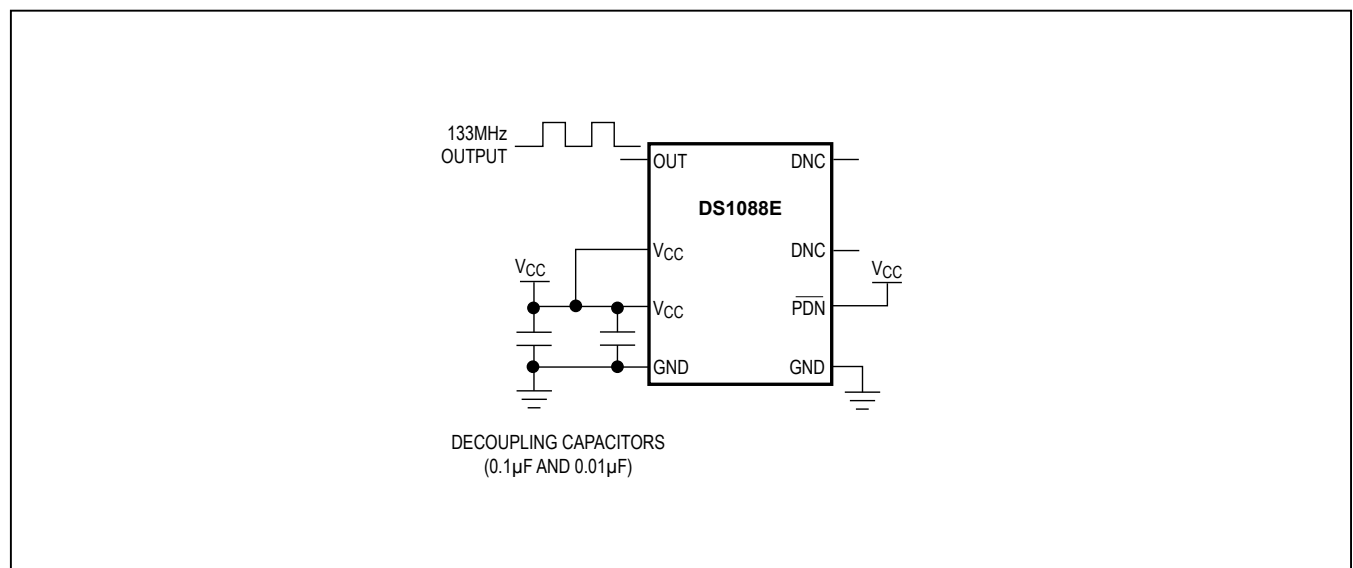

Absolute Maximum Ratings

(Voltages relative to ground.)

Voltage Range on V_{CC}-0.5V to +6.0V
 Voltage Range on \overline{PDN}-0.5V to ($V_{CC} + 0.5V$)*
 Operating Temperature Range..... -40°C to +95°C

Storage Temperature Range..... -55°C to +125°C

Lead Temperature (soldering, 10s) +300°C

Soldering Temperature (reflow)..... +260°C

*Not to exceed +6.0V.

Stresses beyond those listed under "Absolute Maximum Ratings" may cause permanent damage to the device. These are stress ratings only, and functional operation of the device at these or any other conditions beyond those indicated in the operational sections of the specifications is not implied. Exposure to absolute maximum rating conditions for extended periods may affect device reliability.

Recommended Operating Conditions

($T_A = -40^\circ\text{C}$ to $+95^\circ\text{C}$, unless otherwise noted.)

PARAMETER	SYMBOL	CONDITIONS	MIN	TYP	MAX	UNITS
Supply Voltage	V_{CC}	(Note 1)	2.85		3.63	V
High-Level Input Voltage (\overline{PDN})	V_{IH}		$0.7 \times V_{CC}$		$V_{CC} + 0.3$	V
Low-Level Input Voltage (\overline{PDN})	V_{IL}		-0.3		$0.3 \times V_{CC}$	V

DC Electrical Characteristics

($V_{CC} = 2.85\text{V}$ to 3.63V , $T_A = -40^\circ\text{C}$ to $+95^\circ\text{C}$, unless otherwise noted.)

PARAMETER	SYMBOL	CONDITIONS	MIN	TYP	MAX	UNITS
High-Level Output Voltage (OUT)	V_{OH}	$I_{OH} = -4\text{mA}$, $V_{CC} = \text{MIN}$	$V_{CC} - 0.4$			V
Low-Level Output Voltage (OUT)	V_{OL}	$I_{OL} = 4\text{mA}$			0.4	V
High-Level Input Current (\overline{PDN})	I_{IH}	$V_{CC} = 3.63\text{V}$			1	μA
Low-Level Input Current (\overline{PDN})	I_{IL}	$V_{IL} = 0\text{V}$	-1			μA
Supply Current (Active)	I_{CC}	$V_{CC} = 3.63\text{V}$, $C_L = 15\text{pF}$, $f_O = 133\text{MHz}$		15	24	mA
Standby Current (Power-Down)	I_{CCQ}	Power-down mode			10	μA

Oscillator Characteristics

($V_{CC} = 2.85\text{V}$ to 3.63V , $T_A = -40^\circ\text{C}$ to $+95^\circ\text{C}$, unless otherwise noted.)

PARAMETER	SYMBOL	CONDITIONS	MIN	TYP	MAX	UNITS
Output Frequency Range Available	f_O			133.3		MHz
Output Frequency Tolerance	$\Delta f/f_O$		-15		+5	%

AC Electrical Characteristics

(V_{CC} = 2.85V to 3.63V, T_A = -40°C to +95°C, unless otherwise noted.)

PARAMETER	SYMBOL	CONDITIONS	MIN	TYP	MAX	UNITS
Power-Up Time	$t_{POR} + t_{STAB}$	(Note 2)			100	μs
OUT Disabled After Entering Power-Down Mode	t_{PDN}	(Note 3)			7	μs
Load Capacitance	C_L	(Note 4)		15	50	pF
Output Duty Cycle (OUT)				55		%

Note 1: All voltages are referenced to ground.

Note 2: This indicates the time elapsed between power-up and the output becoming active. An on-chip delay is intentionally introduced to allow the oscillator to stabilize. t_{STAB} is equivalent to approximately 512 clock cycles and will depend on the programmed oscillator frequency.

Note 3: Output disabled in two cycles or less of the output frequency.

Note 4: Output voltage swings may be impaired at high frequencies combined with high-output loading.

Typical Operating Characteristics

($V_{CC} = 3.3V$, $T_A = +25^\circ C$, unless otherwise noted.)

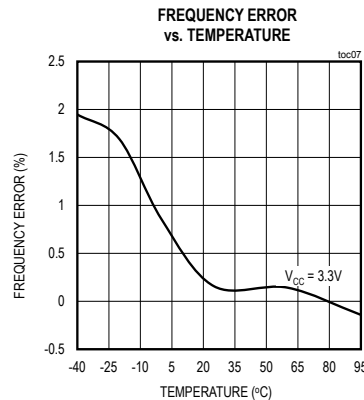
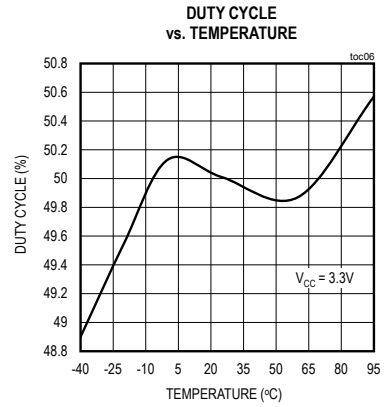
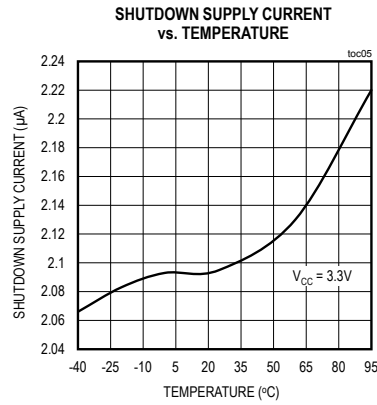
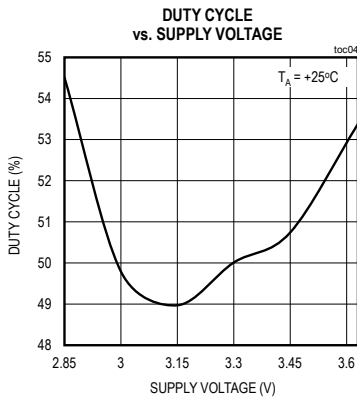
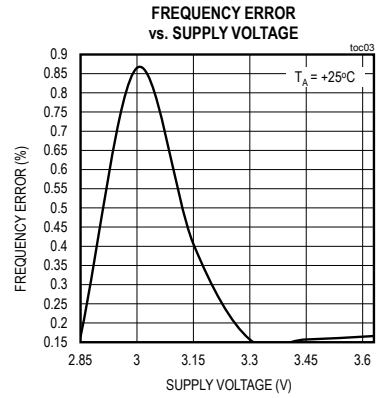
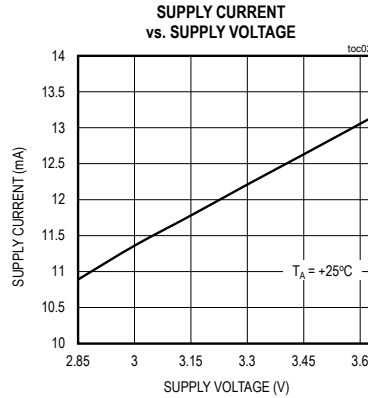
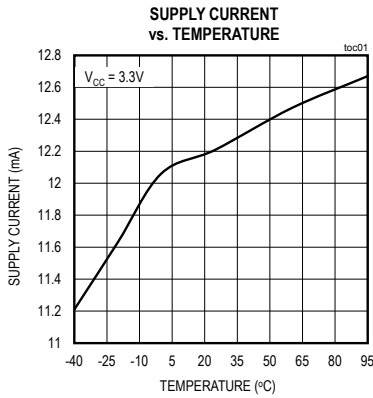

Pin Configuration

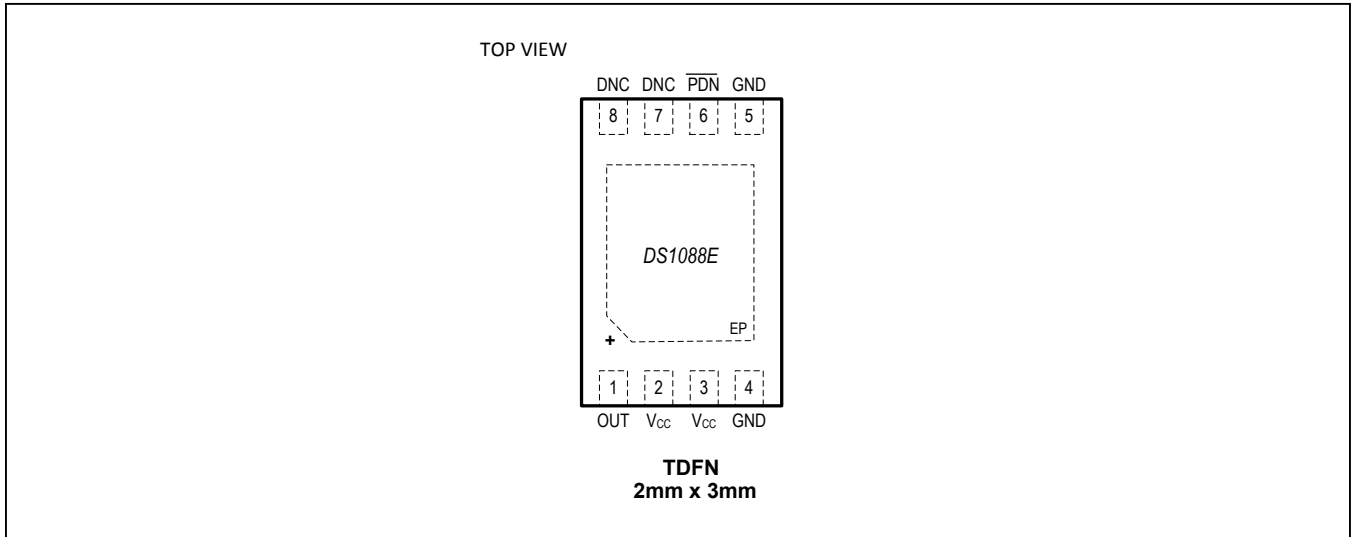

Pin Description

PIN	NAME	FUNCTION
1	OUT	Oscillator Output
2, 3	V _{CC}	Power Supply
4, 5	GND	Ground
6	$\overline{\text{PDN}}$	Active-Low Power-Down. When the pin is high, the oscillator is enabled. When the pin is low, the oscillator is disabled (power-down mode).
7, 8	DNC	Do Not Connect. The DNC pins are internally connected to ground.
EP	—	Exposed Pad. Internally connected to GND. Connect to the ground plane to minimize noise injection. Not intended for use as the device electrical ground.

Detailed Description

The DS1088E is a low-cost clock generator that produces a square-wave output without external timing components. The fixed-frequency oscillator is available in a factory-calibrated frequency of 133MHz. The device has a power-down pin for power-sensitive applications. A block diagram of the device is shown in [Figure 1](#).

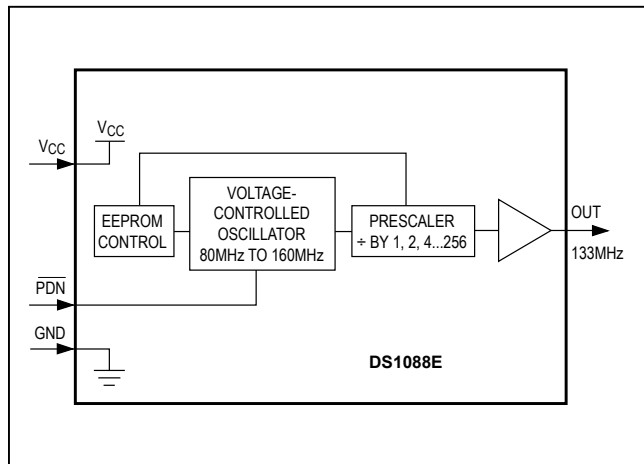

Figure 1. Block Diagram

Output Frequency

The internal oscillator frequency is divided by the factory-programmed prescaler to produce an output frequency of 133MHz.

Power-Down Mode

The $\overline{\text{PDN}}$ pin disables the internal oscillator and the oscillator output for power-sensitive applications. The power-down pin must remain low for at least two output frequency cycles plus 10 μs for deglitching purposes. On power-up, the output is disabled until power is stable and the voltage-controlled oscillator has generated 512 clock cycles.

Applications Information

Power-Supply Decoupling

To achieve the best results when using the device, the power supply must be decoupled with 0.01 μF and 0.1 μF high-quality, ceramic, surface-mount capacitors. Surface-mount components minimize lead inductance, which improves performance, and tend to have adequate high-frequency response for decoupling applications. These capacitors should be placed as close as possible to the V_{CC} and GND pins.

Ordering Information

PART	FREQUENCY (MHz)	TEMP RANGE	PIN-PACKAGE
DS1088EN-133+T	133.3	-40°C to +95°C	8 TDFN-EP*

+Denotes a lead(Pb)-free/RoHS-compliant package.

T = Tape and reel.

*EP = Exposed pad.

Package Information

For the latest package outline information and land patterns (footprints), go to www.maximintegrated.com/packages. Note that a "+", "#", or "-" in the package code indicates RoHS status only. Package drawings may show a different suffix character, but the drawing pertains to the package regardless of RoHS status.

PACKAGE TYPE	PACKAGE CODE	OUTLINE NO.	LAND PATTERN NO.
8 TDFN-EP	T823+1	21-0174	90-0091

Chip Information

SUBSTRATE CONNECTED TO GROUND

Revision History

REVISION NUMBER	REVISION DATE	DESCRIPTION	PAGES CHANGED
0	11/13	Initial release	—

For pricing, delivery, and ordering information, please contact Maxim Direct at 1-888-629-4642, or visit Maxim Integrated's website at www.maximintegrated.com.

Maxim Integrated cannot assume responsibility for use of any circuitry other than circuitry entirely embodied in a Maxim Integrated product. No circuit patent licenses are implied. Maxim Integrated reserves the right to change the circuitry and specifications without notice at any time. The parametric values (min and max limits) shown in the Electrical Characteristics table are guaranteed. Other parametric values quoted in this data sheet are provided for guidance.